



Pump • Fire Fighting Units • Booster Set

## **GENERAL INFORMATION ABOUT BOOSTER PUMPS**

### **What is booster pump ?**

The pressurization systems which takes low pressured water from a tank or directly from city network and provide it with required flow rate and pressure are called booster pumps. Their operations are completely automatic according to intended use.

Depending on the intended use, boosters are generally classified as follows;

- Domestic Water Booster Pumps
- Irrigation System Booster Pumps
- Process Water Booster pumps

### **According to which Standarts booster pumps should be selected ?**

Until today, in Europe, widely accepted standart which describes pressurization systems comprehensively is DIN 1988. Domestic water booster pumps are defined in DIN 1988-5, how and under what conditions they are selected and used are described.

The European Union EN 806 standard is valid in the countries of European Union members. However, in some cases it is still being in reference to DIN 1988 norm. Therefore, there is no problem with selections and calculations based on the DIN 1988 standard. Selection and calculation methods in this catalog are taken from DIN 1988-5 and EN 806 standards.

### **Which parameters should be determined before selecting booster ?**

The first condition for long-life booster is selecting according to suitable operating and environmental conditions and determining pump capacities correctly.

In choosing type of booster;

- Positioning of water tank relative to the booster (Does the water come on its own? Or is suction needed?)
- Characteristic of the space where booster will be installed (Is there enough space and air circulation?)
- Correct selection of the number of users and diversity factor
- Properties of the water to be pressurized (hardness, temperature)
- Required head
- Required flow rate and the volume of the expansion tank to be selected

When pump and equipments according to these material and functional characteristics are selected, the right type of booster pump which will be able to work without problems for many years.

### **How to determine operating pressure range of booster system ?**

The pressure in the outlet collector of the booster is the sum of the intake pressure in the inlet collector and the pressure generated by the booster. However, in Turkey boosters are generally supplied from a tank at the same level with the booster and open to atmosphere, so the inlet pressure of the booster is negligible.

While determining operating pressure of booster;

- The static height of the building
- The minimum flow pressure on top floors
- Friction losses in the pipes
- Water meter losses
- Filters and other equipments losses should be calculated.

Minimum pressure of the booster, if there is no special conditions defined by the user, should be approximately 10-15 mwc on the highest settlement or the most critical user

$$H_{bot} = DPe + Pmin\ fl + S ( l \times R + DpF) + DPwm + DPap - SPLN \quad \text{(Formula 1)}$$

- $H_{bot}$  : Booster bottom pressure
- $DPe$  : Building height (mWc)
- $Pmin\ fl$  : Minimum flow pressure (mWc)
- $S ( l \times R + DpF)$  : Friction losses in pipes (mWc)
- $DPwm$  : Water meter losses (mWc)
- $DPap$  : Losses of filter and other equipments if known (mWc)
- $SPLN$  : Minimum pressure at the booster inlet (mWc)

SPLN is often neglected in applications that booster is fed from a tank. However on some cases (especially oil filling plants), towers are used as water tanks. On that situation, 15-20 mWc inlet pressure is generated.

Another type of connection is to take water directly from the pressurized network and pressurize it where the network pressure is not enough. If this is the case, inlet pressure must be calculated.

Calculation of total losses in the installation may not always be easy. To do this, it is necessary to know the types, quantities and measurements of any fixtures, valves, pipes and fittings and to calculate the losses in the water flow that will pass through them.

Example of bottom pressure calculation:

- Building Height = 30m
- Minimum flow pressure = 15m
- Total loss of installation = 7,5m
- Water meter loss = 7,5m
- Filter and otlr losses = 0 m
- Inlet pressure = 0 m

Let's calculate bottom pressure value of a booster to be selected for an old apartment

$$H_{bot} = DPe + Pmin\ fl + S ( l \times R + DpF) + DPwm + DPap - SPLN$$

$$H_{bot} = 30 + 15 + 7,5 + 7,5 + 0 - 0$$

$$H_{bot} = 60\ mSS$$

The pressure difference called as operating pressure of the booster ( $H_{üst}-H_{alt}$ ) should be as small as possible and the booster should be intended to give a constant pressure. As this value increases, surge pressure in the installation increases and the comfort of use decreases.

Therefore, ( $H_{top}-H_{bot}$ ) 1,5 – 2bar difference as operating range is generally adequate and it is tried to be applied. This difference should not exceed 2.5 bar.

$$H_{top} = H_{bot} + 15\ mWc$$

$$H_{top} = 75\ mWc$$

According to this, our operating pressure is 60-75 mWc.

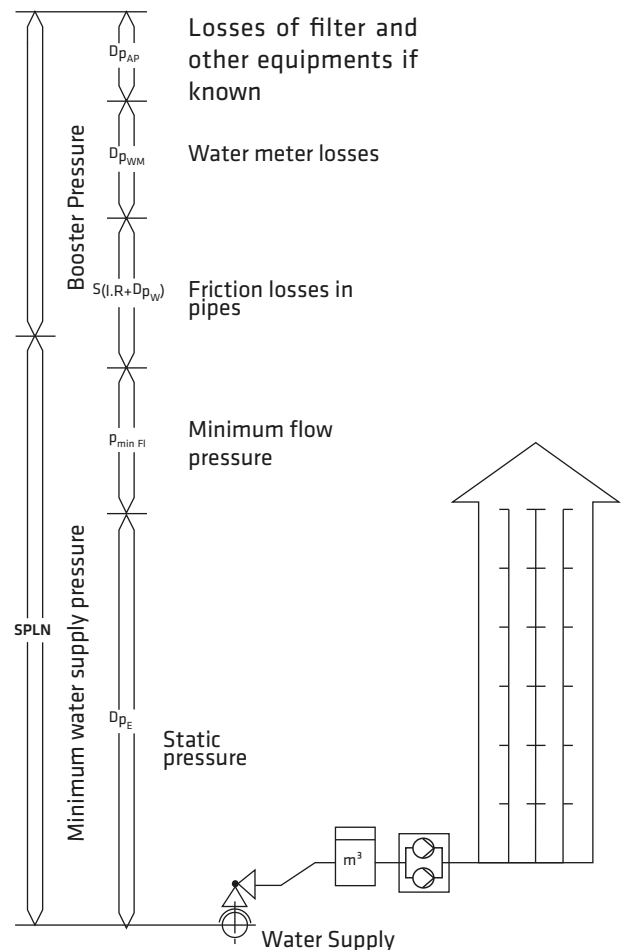

Figure 1

Another point to be aware of when calculating the required pressure to be ensured by the booster is that static water pressure should not exceed 5 bar (50mWc) at any point in the installation.

To ensure comfortable use of water and proper operation of fixtures, DIN 1988 standart requires the use of pressure reducer or zoning the installation (regional pressurization) if the inlet pressure exceeds 5 bar. (figure 2)

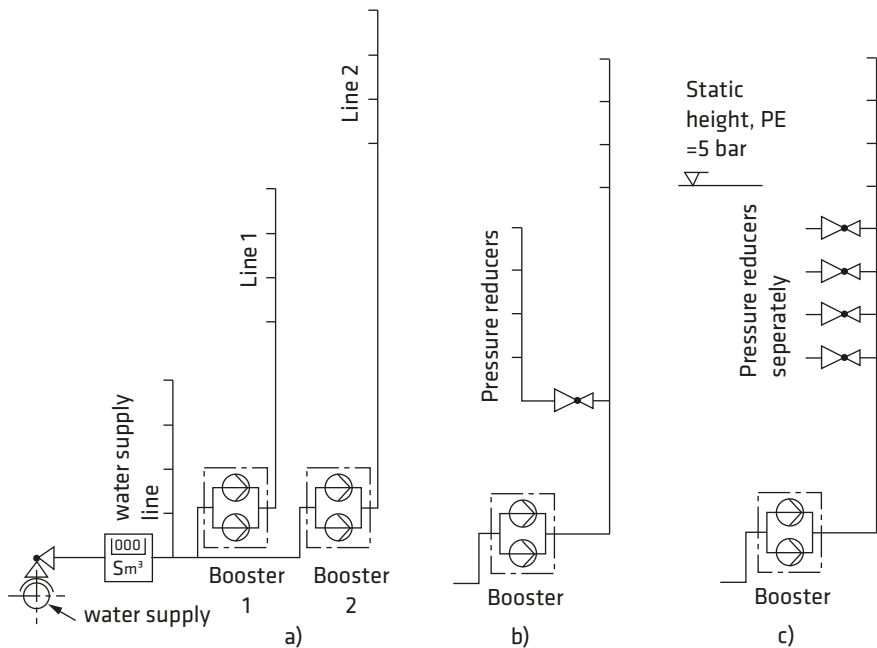

Figure 2

**How to determine flow rate of booster system?**

Number of flats	Factor of multi-user
4	0,66
5-10	0,45
11-20	0,40
21-50	0,35
51-100	0,30
more than 100	0,25

Table 1

Application Areas	Daily Average. (lt/day)
Corporate housing	150
Luxury housing	200
Luxury Villas	225
Guesthouses	100
Hotels	150
Hospitals	200
Offices	80
Schools	20
Boarding Schools	100
Malls	50

Table 2

Calculation of flow rate has two main criteria. First one is estimated volume of water in unit of time. The other is diversity factor of multi-user systems. We are going to use both criteria when calculating domestic water boosters.

**Example of flow rate calculation:**

Let's figure out the flow rate of a site where 100 families live in. EN806 standardında belirtilen formüle göre;

$$Q = \frac{A \times B \times T \times f}{1000} \quad \text{(Formula 2)}$$

- \*Q=Booster flow rate (m<sup>3</sup>/h)
- \*A=Number of flats
- \*B= Number of individuals in the family
- \*T= Daily average water consumption of the individual (liter /day)
- \*f= Diversity factor

We may take the number of individuals as 4-5 per average family in Turkey. We will use Table 1 for diversity factor and Table 2 for Daily average water consumption. According to this;

$$Q = \frac{100 \times 4 \times 150 \times 0,30}{1000} = 18 \text{ m}^3/\text{h}$$

According to this result, we can select a single pump booster that provides 18 m<sup>3</sup>/h flow rate. However, as in the above example, it is more accurate to select multiple pump boosters in crowded places such as hospitals.

According to DIN standards pumps must be selected with backups. While the selected spare pump is not working, other operating pumps total flow rate should be equal to our calculated booster flow rate, which is 18 m<sup>3</sup>/h

According to this;

- 2x 18 m<sup>3</sup>/h or
- 3x 9 m<sup>3</sup>/h or
- 4x 6 m<sup>3</sup>/h might be selected

## CALCULATION AND SELECTION METHODS OF MEMBRANE EXPANSION/PRESSURED TANKS

Small volume membrane expansion tanks in booster sets, according to producers preference, are used from several liters to 5000 liter capacities. Membrane expansion tanks are produced in various types and capacities such as vertical, horizontal, footed and non-footed. Nowadays, the use of expansion tanks that have membrane made out of Butyl, EPDM or natural rubber separation for water and gas parts has become widespread.

When these tanks are not used or for example their membranes are exploded, irregularities occur in booster's start/stop functions and that causes operation difficulties.

The purpose of using membrane tanks connected to the discharge lines of booster sets is limiting number of switches of booster pumps.

Electric motor manufacturers switch number recommendation is around S=20-30 / hour. That means, more than 20-30 times of start/stop in an hour for motors is not recommended. Continuous start/stop function not only shortens the service life of electrical motor, pump parts and electrical panel equipments but also increases electrical energy consumption due to starting current. Therefore, especially for motors bigger than 3kW, it is advisable to limit switch number.

Absorbing possible system shocks, keeping the pressurized water in a certain amount as a reserve in short power cuts are other purposes of the use of these tanks.

In section 5 of DIN 1988 standard estimated volume calculation for membrane expansion tanks is developed based on calculation of pressure controlled air cushioned expansion tank in DIN 4810 standard.

Accordingly, the nominal volume of the expansion tank to be selected is calculated according to the Formule 3.

$$VE = 0,33 \times V_{max} \frac{H_{top} + 1}{(H_{top} - H_{bot}) \times S} \quad \text{(Formula 3)}$$

- VE : Nominal volume of selected tank (liter)
- V<sub>max</sub> : Flow rate of a pump at H bottom pressure (m<sup>3</sup>/hour)
- H<sub>top</sub> : Booster's set top pressure (bar)
- (H<sub>top</sub> - H<sub>bot</sub>) : Booster's set operating pressure difference (bar)
- S : Required number of switch (1/ hour)

### Example of membrane nominal volume calculation

In an example, the booster set wich has H<sub>alt</sub> equals to 45 mSS, H<sub>üst</sub> equals to 65 mSS and 44 m<sup>3</sup>/hour are given. Also the number of pump in booster set is four wich are working rotatory. The required number of switch is given 30/hour.

- V<sub>max</sub> = 44 / 4 = 11 m<sup>3</sup>/saat (maximum flow rate of a pump)
- H<sub>top</sub> = 6,5 bar
- H<sub>bot</sub> = 4,5 bar
- S = 30 / hour

The nominal volume of required membrane expansion tank (VE)

$$VE = 0,33 \times 11 \frac{6,5 + 1}{(6,5 - 4,5) \times 30} = 0,453 \text{ m}^3 = 453 \text{ lt}$$

The nominal volume of the tank is 500 liters. In the operating conditions of this tank, the useful water volume (VF)

$$VF = VE \frac{H_{top} - H_{bot}}{H_{top} + 1} \quad \text{(Formula 4)}$$

$$VF = 500 \frac{6,5 - 4,5}{6,5 + 1} = 133 \text{ liters are calculated.}$$

Another criteria in membrane expansion tank selection is pressure class that tank should have.

The zero flow rate pressures of the pumps used in boosters are determining the pressure class of the tank. Tank nominal operating pressure should be higher than zero flow rate pressures of pumps.

The pre-air pressure of the tank is dependent of operating conditions and should be set to a value that 10% lower than the  $H_{bot}$  operating pressure.

In the above example booster application with  $H_{bot} = 45$  mWc, pre-gas pressure of required membrane expansion tank should be set to approximately  $40$  mWc = 4 bar.

There are varios methods of connecting membrane tanks to the booster's discharge line. Generally, one side of the pressure collector connects to the tank and the other side to the installation. It is also possible to connect the tank to anywhere on building's installation line.

Important point of making connections is that the connections can be quickly detached for membrane change or equivalent situation and can be isolated from installation by using an additional valve.

ACCORDING TO PUMP TYPES RECOMMENDED MINIMUM TANK VOLUMES			
SB M/T 80 PUMPS	100 lt.	CDLF 4 PUMPS	200 lt.
SB M/T 90 PUMPS	200 lt.	CDLF 8 PUMPS	300 lt.
SB M/T 100 PUMPS	300 lt.	CDLF 12 PUMPS	500 lt.
SB /T 130 PUMPS	500 lt.	CDLF 16 PUMPS	500 lt.
GRV VD PUMPS	200 lt.	CDLF 20 PUMPS	750 lt.
GRV VB PUMPS	300 lt.	CDLF 32 PUMPS	750 lt.
SKMV 32 PUMPS	500 lt.	CDLF 42 PUMPS	1000 lt.
SKMV 40 PUMPS	750 lt.	CDLF 65 PUMPS	2x1000 lt.
SKMV 50 PUMPS	1000 lt.	CDLF 85 PUMPS	2x1500 lt.
SKMV 65 PUMPS	2x1000 lt.		

Table 3

## INSTALLATION OF BOOSTERS

Boosters can operate connected to a tank or directly to city network. (Figure 3)

For directly connected to city network boosters, it is precondition that inlet pressure is not surging more than 1 bar and is not lower than 0,5 bar. In networks with unfulfilled regarding conditions, it is not true to connect the booster directly to the city network. Due to inadequacy in network pressures, this system is rarely used in Turkey.

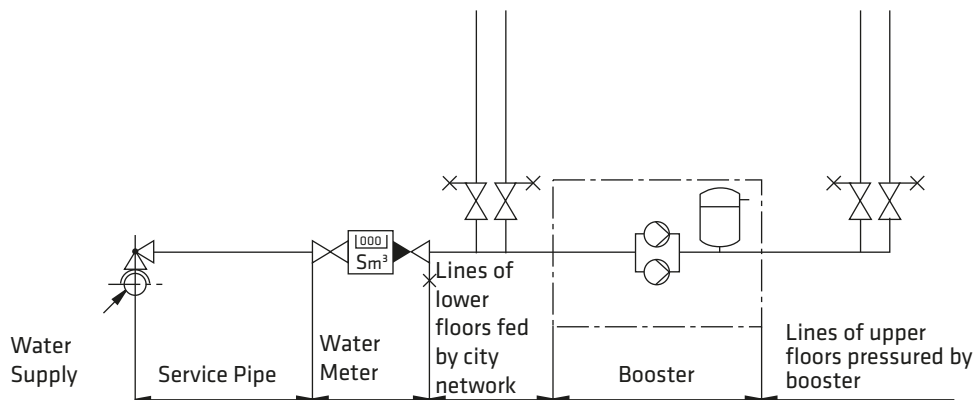

Figure 3

In a booster system that operates by taking water from a tank, the water must be able to flow towards the pump by its own weight and a pre-pressure of about 0.2 bar must be generated at the suction port of the pump.

Operation of the booster by suction is actually not correct. However, when this is forced to, the installation should be designed using a pipe whose internal diameter is at least one diameter wider than the suction mouth of the pump. From the shortest possible path, the installation should be determined using the least amount of elbow and fittings. Valve diameter should be kept as large as possible. It is mandatory that each pump has a separate suction line.

# Installation Types

## Sample Installation with Suction Height

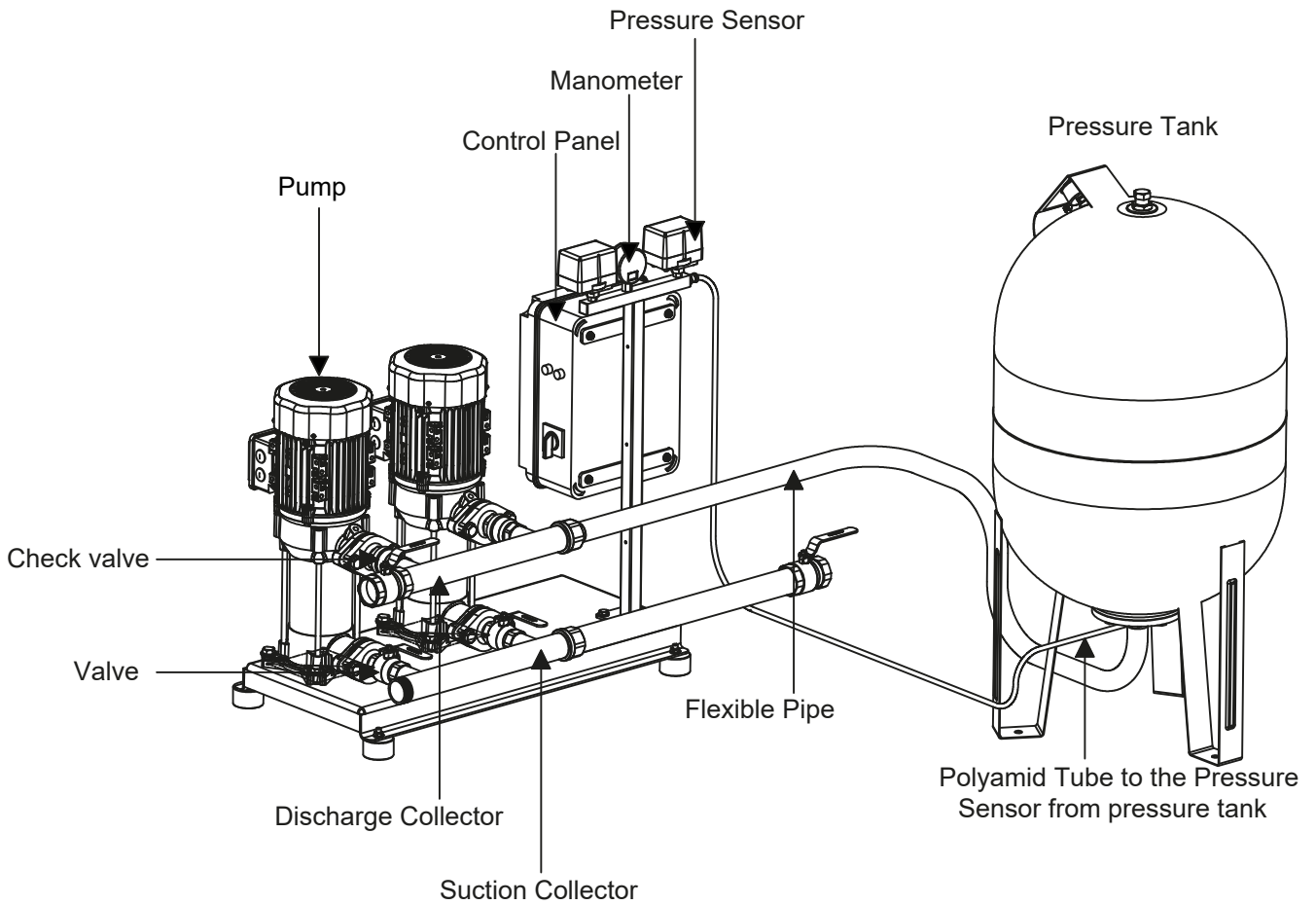
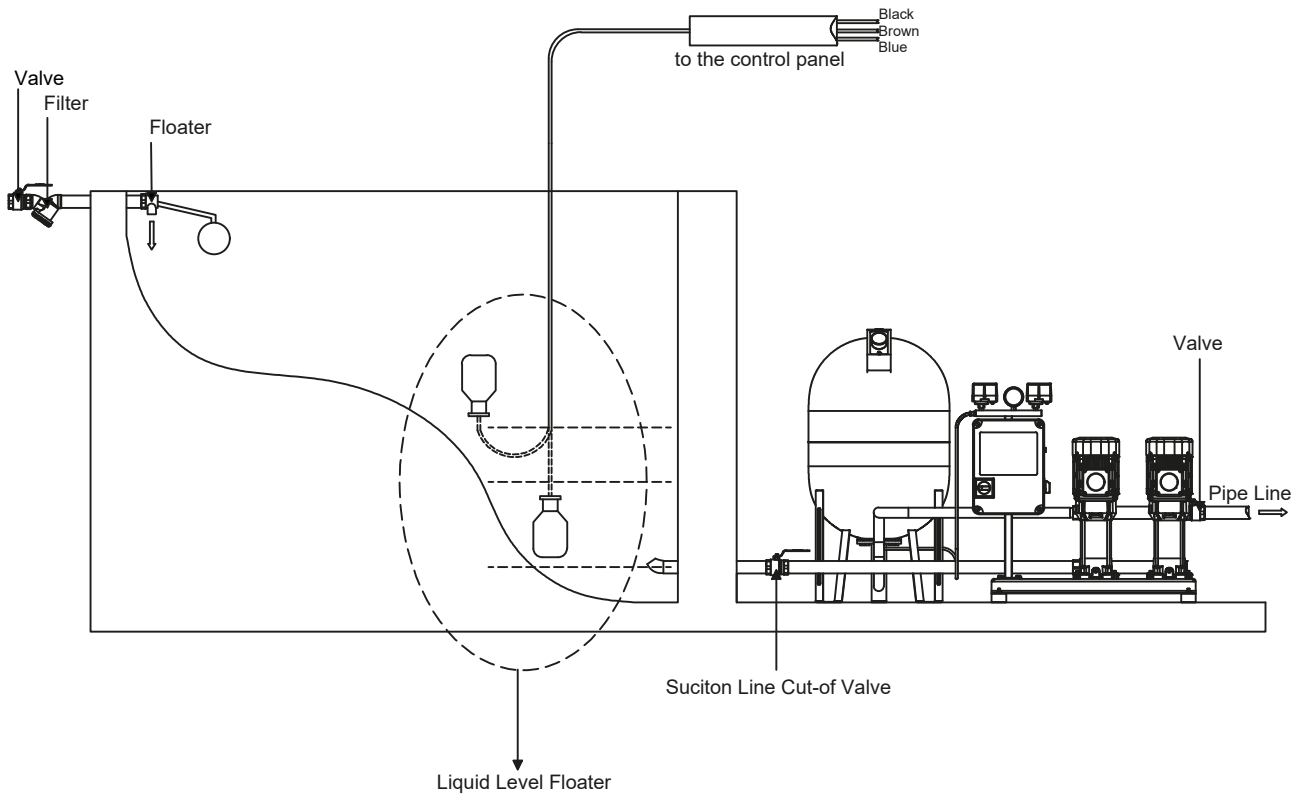

# Sample Installation with Suction Depth

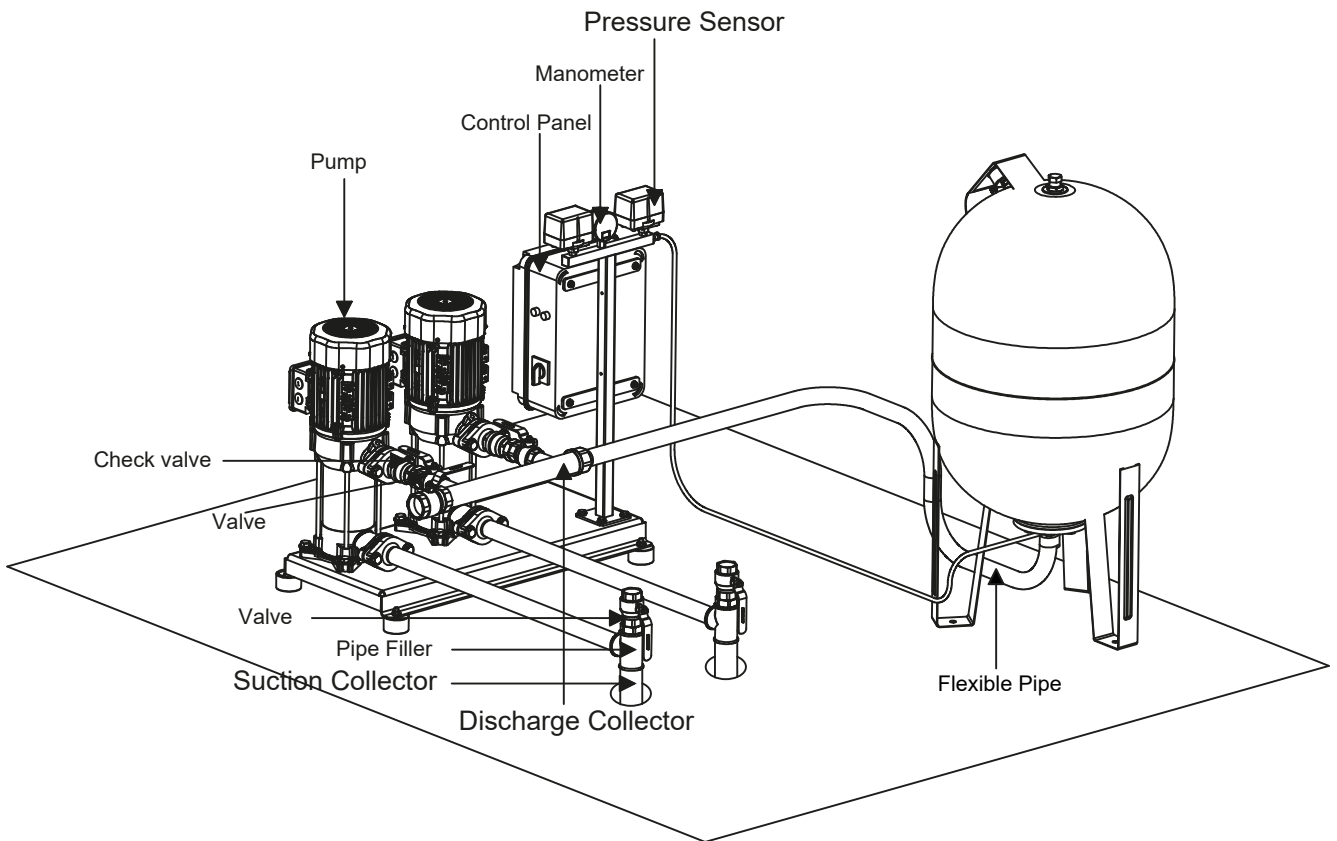
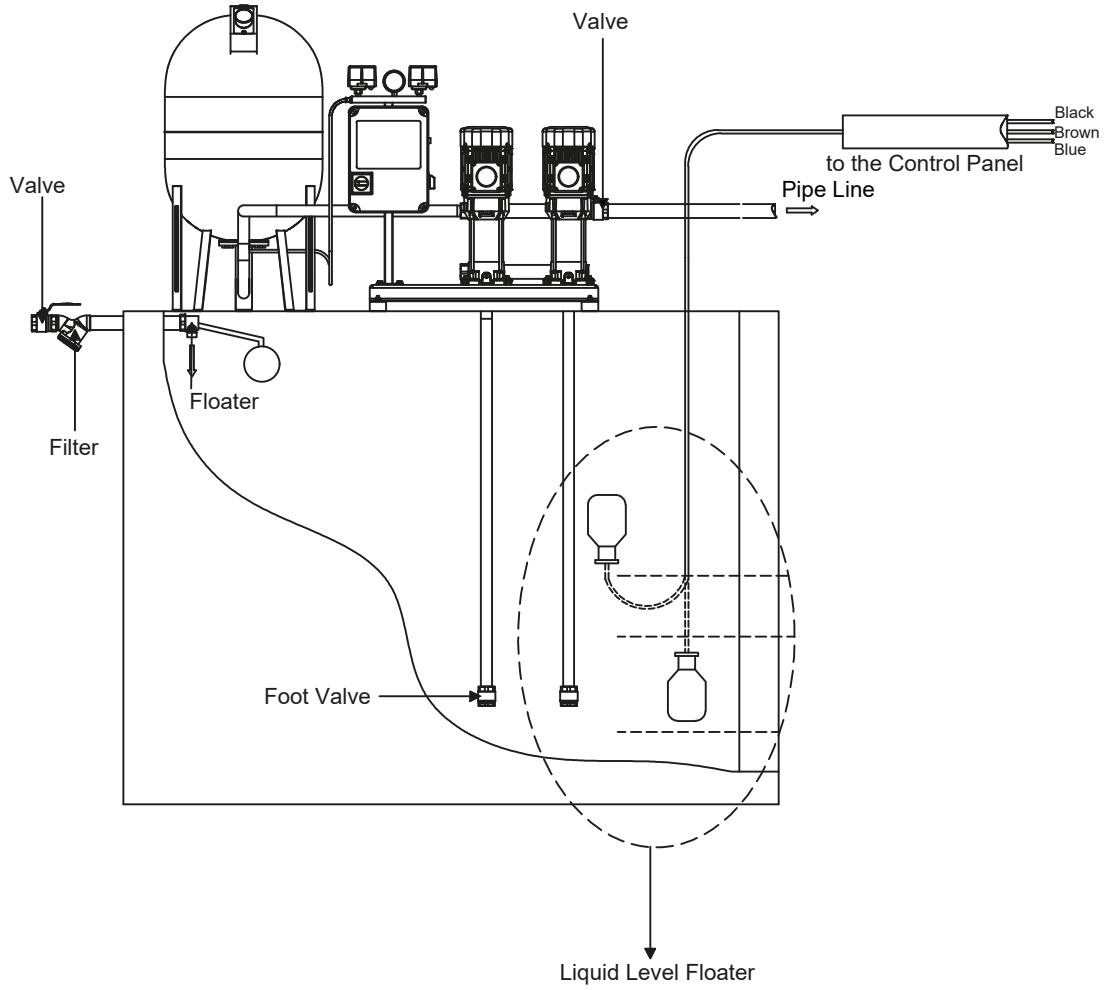

## Control Panel Options

Two types of panels are used as standard in boosters.

- The first is pressure switch controlled electrical panels. These panels are run/stopped according to pressure signal received from each pump's separated pressure switches. In this type panel boosters, sufficient volume of expansion tank is used for minimizing number of switches.

- The second is frequency controlled electrical panels. Comfort is important in regarding facilities using these panels. Pressure information received from Transmitter is run on the frequency inverter's PFC macro or PLC and keeps the line pressure constant by reducing the pump's rate according to system flow rate. In this type of panel booster, an expansion tank with a lower volume than the first type is used.

## Pressure Switch Controlled Panel Properties

- Works with 380-460 V AC 50 Hz / 60 Hz mains voltage.
- Panel frame is made of thermoplastic material with IP 54 protection class or manufactured from DKP sheet and painted with RAL 7032 electrostatic paint.
- Panels have Manuel - 0 - Automatic selector switch.
- Panels in Automatic position;
  - Protection with floater against waterless operation
  - Protection against phase interruption and imbalance
  - There is co-aging execution by changing turns on each operation.
- During panel's protection relay failure, it works via pressure switches on Manuel position against waterless operation.



Figure 7: Front view of pressure switch controlled panel with triple pump

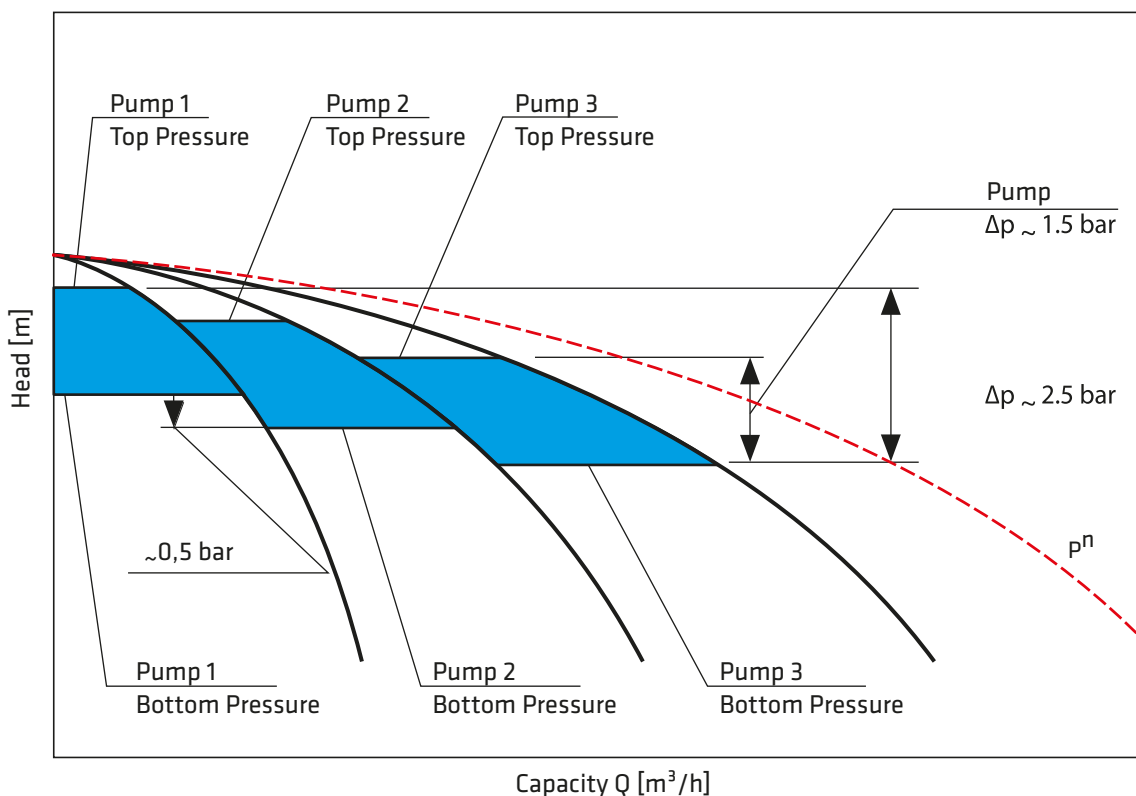

Figure 8. Control Panel With Pressure Sensors



## Frequency controlled panel properties

- Works with 380-460 V AC 50 Hz / 60 Hz mains voltage.
- Panel frame is painted with IP 54 protection classed RAL 7032 electrostatic paint
- Panels have ventilation and filter.
- Panel switch can be controlled from front panel.
- Frequency converter device has overheat, motor overheat, motor overcurrent, short circuit, earth leakage, non-overload fault, motor phase loss, over and undervoltage protection and as standard internal EMC and entry shock coil.
- Panel is protected against mains phase loss imbalance and phase reversal.
- During phase fault, user is warned by signal lamps.
- For motors and frequency converter, there are separate thermal motor protection switches and fuses.
- Up to 4 pump applications in the PFC Macro system, system automation is controlled through PFC macro software and advanced LCD panel by an electronic card on the converter.
- When the number of pumps are 5 or more in PLCOPRT system, PLC and touch panel are used. Via software in the PLC, system automation is controlled by touch panel.
- Upon request, optionally, PLC operator system can be provided in all multi pumps.
- Up to 7,5 kW pumps are operated on direct start, 11 kW and above are operated on star-delta start. Optionally, instead of star-delta start soft start can be used.
- For each motor there are separate ON/OFF keys. Moreover, system can be operated as Automatic or Manual by separate switch.
- In AUTO position, in the PFC MACRO system, the pressure information from the 1 pressure sensor at the pumps collector output is input to the converter in 4-20mA as analogue. The control software adjusts the pump speed as to provide outlet pressure to the set pressure value from operator panel. When the required pump capacity is exceeded, a second pump is switched on from the network and the pump running on the converter adapts itself according to the new situation and provides regulation. In each additional pump the situation continues in the same way. When the need for water decreases, the pump goes to standby. It steps in again if needed and continues to work in the same way. When there is a problem with any pump, the pump is switched on automatically. After each standby state, the pump entering the circuit runs in sequence.

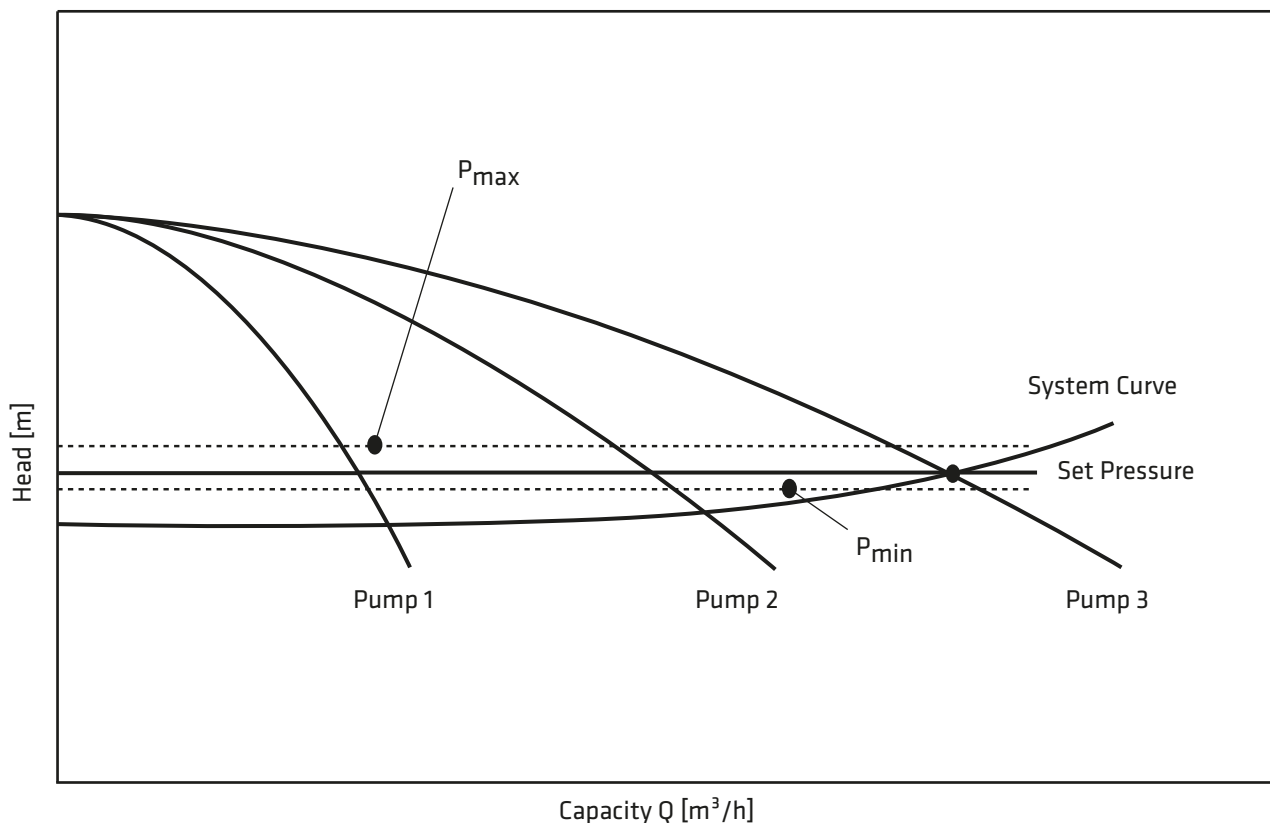

Figure 9. Frequency Controlled Booster

•The operation in PLC OPRT system in AUTO mode is same as above. The pressure sensor is connected to the PLC and the pumps are controlled via the software in the PLC. System information entries are made via the operator touch panel located on the panel.

•In case of a malfunction on the electronic system or on the converter in MANUEL position, the pumps that are switched on are operated directly or star-delta via the contactors on the panel. In this case, the pressure is adjusted by the pressure switches at the outlet of the collector.

- Separate operating and fault lamp for each motor.
- Lamp for converter failure.
- Lamp for phase protection.
- Dry contact output for general failure.
- Panel is delivered as ready to commissioning.
- The input shock coil is available as STANDARD to reduce the harmonic distortion in the mains supplied by the panel.



Figure 10: Front view of frequency controlled panel with double pump

Minimum Pipe and Valve Diameters for Suction Boosters					
	Suction Pipe	Flap		Suction Pipe	Flap
SB M/T 80	1¼"	1½"	CDLF 4	1½"	2"
SB M/T 90	1½"	2"	CDLF 8	2"	2½"
SB M/T 100	2"	2½"	CDLF 12	2"	2½"
SB T 130	2½"	3"	CDLF 15	2"	2½"
GRV VD	2"	2½"	CDLF 20	2½"	3"
GRV VB	2"	2½"	CDLF 32	2½"	3"
SKMV 32	2"	2½"	CDLF 42	3"	4"
SKMV 40	2½"	3"	CDLF 65	4"	5"
SKMV 50	3"	4"	CDLF 85	4"	5"
SKMV 65	4"	5"			

NOTE: Recommendation for suction pipe diameter is given for steel pipe, if plastic pipe is used diameter of pipe should be increased.

Table 4



Pump • Fire Fighting Units • Booster Set

# TH GRV-VD / VB BOOSTERS

TH GRV-VD / VB Rev.11.09.2021



## General Information

High pressure, quiet running, compact and low power consumption.

GRV-VD / VB pumps are suitable for pumping non-abrasive, clean or slightly contaminated, low viscosity without solid & fibrous particles liquids.

Vertical structure saves space.

## Technical Data

Capacity \_\_\_\_\_ up to 60 m<sup>3</sup>/h

Head \_\_\_\_\_ up to 170 m

Casing Pressure \_\_\_\_\_ 10-16-25 bar

Design Temperature \_\_\_\_\_ up to 50 °C

## Design Features

- TH GRV-VD / VB boosters are manufactured with vertical pump.
- The boosters are produced as single, double and triple pumps as a standard according to the desired flow. Upon request, up to 6 pumps can be set.
- Single-pump boosters have a water level float (electric floater).
- Phase control system (PCS) is available in single pump, three-phase motorized boosters.
- Sequencing, phase control and liquid level control are standard features for multiple pumped booster pumps.
- Booster pumps can operate in two different modes; automatically and manually.

## Booster Designation

# TH 1 x GRV-VD 5

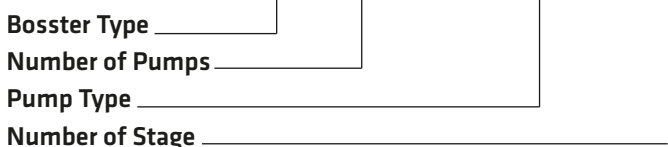

- Electric motors of high efficiency class conforming to IEC 60034-30 standard are used.
- The booster pumps can be manufactured as a variable-speed frequency control for convenience. (upon request)

## Material Information

Part Name	Material	
	Standard	Optional
<b>Pump</b>		
Base Plate	GG 25	Bronz / AISI 304
Stage Casing	NORYL	Bronz / AISI 304
Intermediate Stage	NORYL	Bronz / AISI 304
Impeller	NORYL	Bronz / AISI 304
Shaft	AISI 420	AISI 304
Cover Plate	AISI 304	-
<b>Panel</b>	Pressure Switch Controlled	Frequency Controlled
<b>Collector</b>	Steel	AISI 304
<b>Frame</b>	Steel	Galvanized Steel
<b>Accessories</b>		
Valve	Brass	AISI 304
Check Valve	Brass	AISI 316

## Performance Curve and Dimension Charts

## TH GRV-VD /VB

Pump Type	kW	IEC	A	B	B(max.)	Ka	Kb	h	d	h1	h2	KG						
1x GRV-VD 3	1,5	90S	430	360	480	370	340	700	1 1/4"	100	265	70						
1x GRV-VD 4	2,2	90L						740			305	75						
1x GRV-VD 5	3	100L						780			345	85						
1x GRV-VD 6	4	112M						820			385	100						
1x GRV-VD 7	4							860			427	105						
1x GRV-VD 8	5,5	132S						900			467	125						
1x GRV-VD 9	5,5							940			507	130						
1x GRV-VD 10	7,5							980			547	135						
2x GRV-VD 3	1,5							90S			800	360	660	700	330	2 1/2"	100	265
2x GRV-VD 4	2,2	90L						740										305
2x GRV-VD 5	3	100L	780	345	185													
2x GRV-VD 6	4	112M	820	385	210													
2x GRV-VD 7	4		860	427	215													
2x GRV-VD 8	5,5	132S	900	467	260													
2x GRV-VD 9	5,5		940	507	270													
2x GRV-VD 10	7,5		980	547	275													
3x GRV-VD 3	1,5		90S	1150	360	720	1050	330	3"	100								265
3x GRV-VD 4	2,2	90L	740															305
3x GRV-VD 5	3	100L	780								345	270						
3x GRV-VD 6	4	112M	820								385	305						
3x GRV-VD 7	4		860								427	315						
3x GRV-VD 8	5,5	132S	900								467	390						
3x GRV-VD 9	5,5		940								507	395						
3x GRV-VD 10	7,5		980								547	405						

Pump Type	kW	IEC	A	B	B(max.)	Ka	Kb	h	d	h1	h2	KG						
1x GRV-VB 3	2,2	90L	435	300	465	410	240	700	2"	100	265	70						
1x GRV-VB 4	3	100L						740			305	75						
1x GRV-VB 5	4	112M						780			345	85						
1x GRV-VB 6	5,5	132S						820			386	100						
1x GRV-VB 7	5,5							860			427	105						
1x GRV-VB 8	7,5	160M						900			467	125						
1x GRV-VB 9	7,5							940			507	130						
1x GRV-VB 10	11							980			547	135						
2x GRV-VB 3	2,2							90L			800	360	760	700	330	2 1/2"	100	300
2x GRV-VB 4	3	100L						740										340
2x GRV-VB 5	4	112M	780	380	185													
2x GRV-VB 6	5,5	132S	820	420	210													
2x GRV-VB 7	5,5		860	460	215													
2x GRV-VB 8	7,5	160M	900	500	260													
2x GRV-VB 9	7,5		940	545	270													
2x GRV-VB 10	11		980	600	275													
3x GRV-VB 3	2,2		90L	1150	360	780	1050	330	3"	100								300
3x GRV-VB 4	3	100L	740															340
3x GRV-VB 5	4	112M	780								380	270						
3x GRV-VB 6	5,5	132S	820								420	305						
3x GRV-VB 7	5,5		860								460	315						
3x GRV-VB 8	7,5	160M	900								500	390						
3x GRV-VB 9	7,5		940								545	395						
3x GRV-VB 10	11		980								600	405						

Booster set with one pump

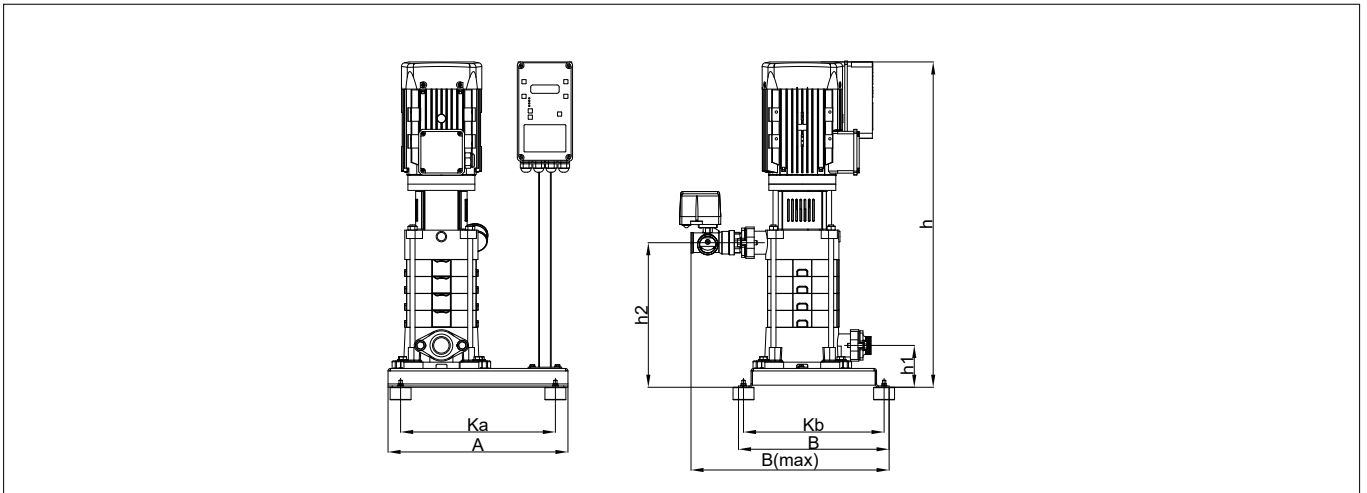

Booster set with two pump

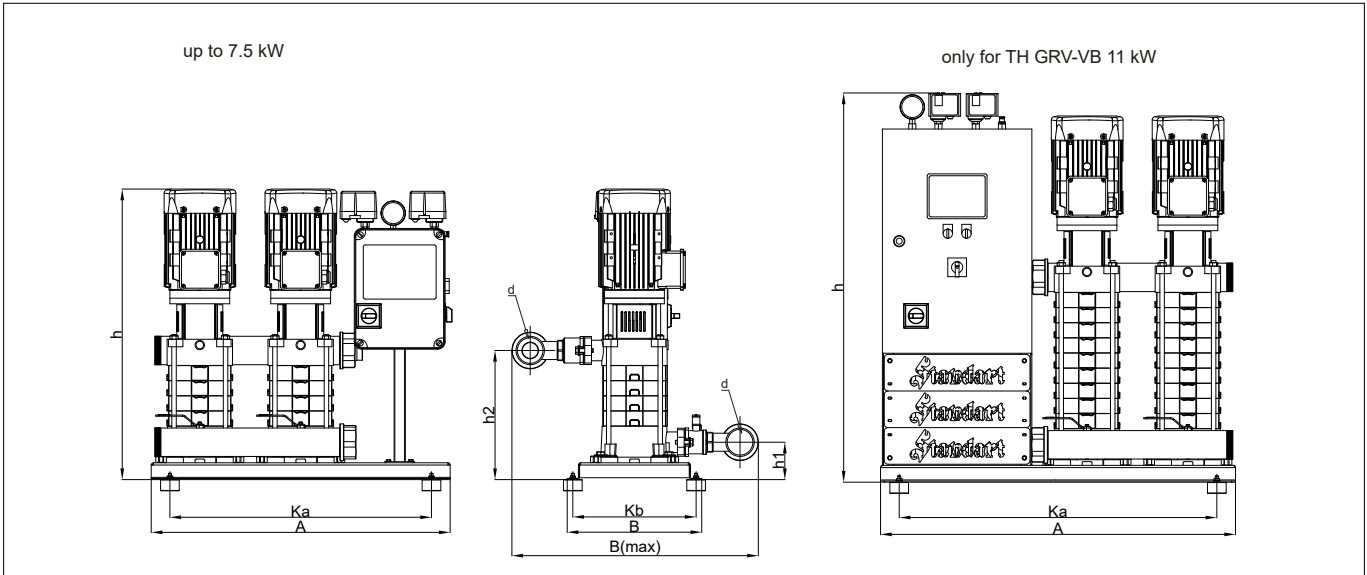

Booster set with three pump

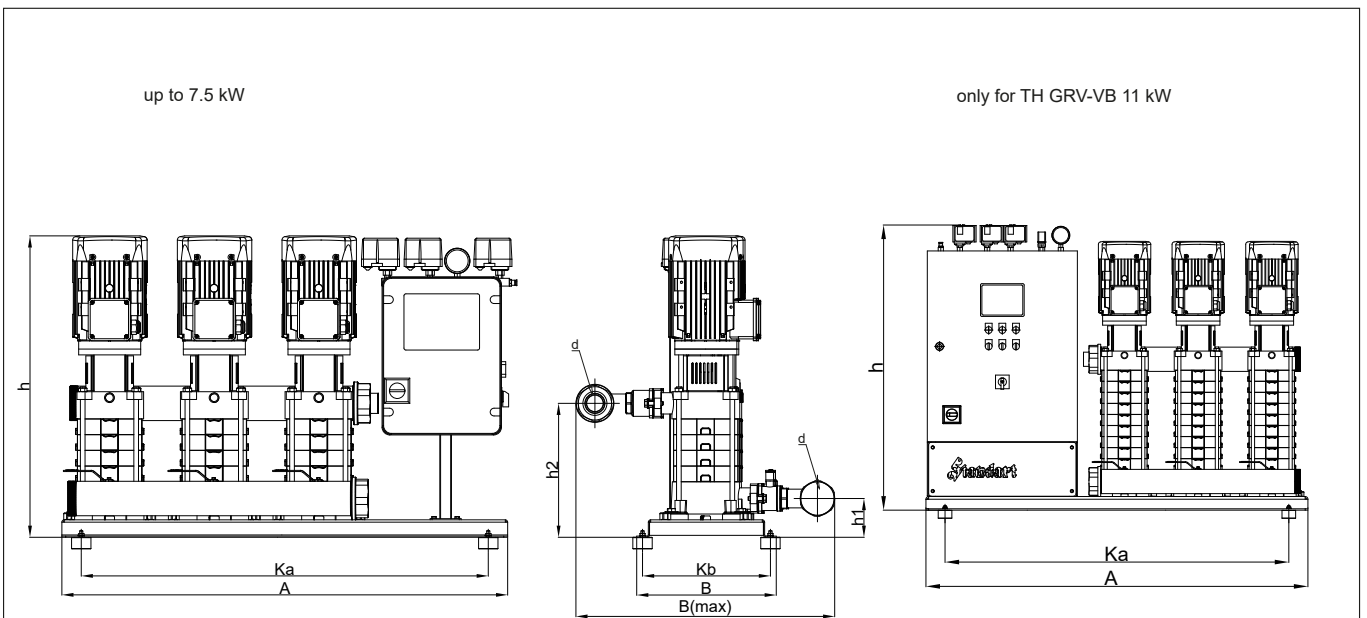

GRV-VD

$n_s = 2900 \text{ rpm}$

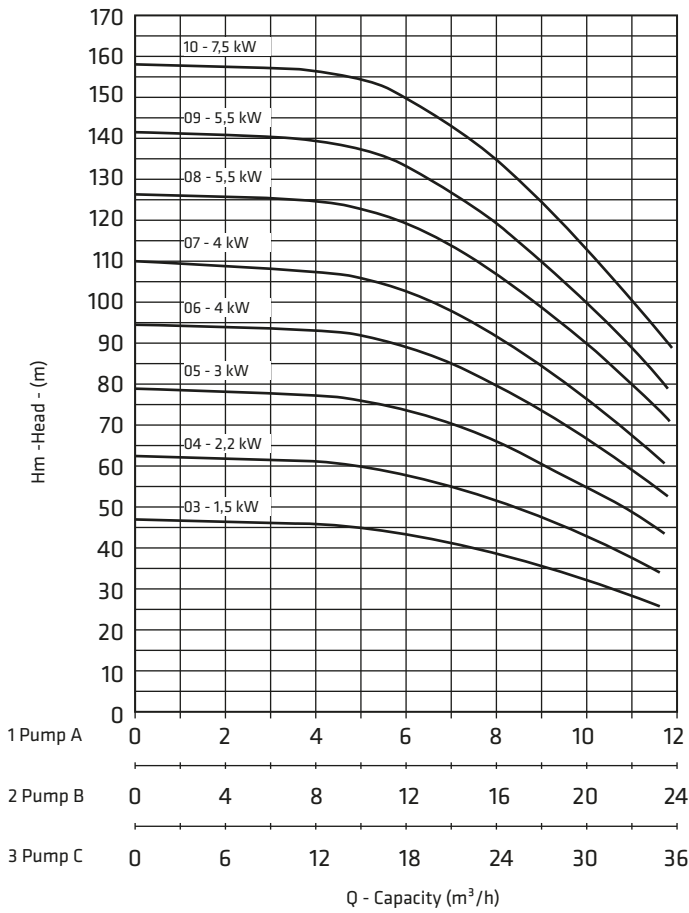

GRV-VB

$n_s = 2900 \text{ rpm}$

