

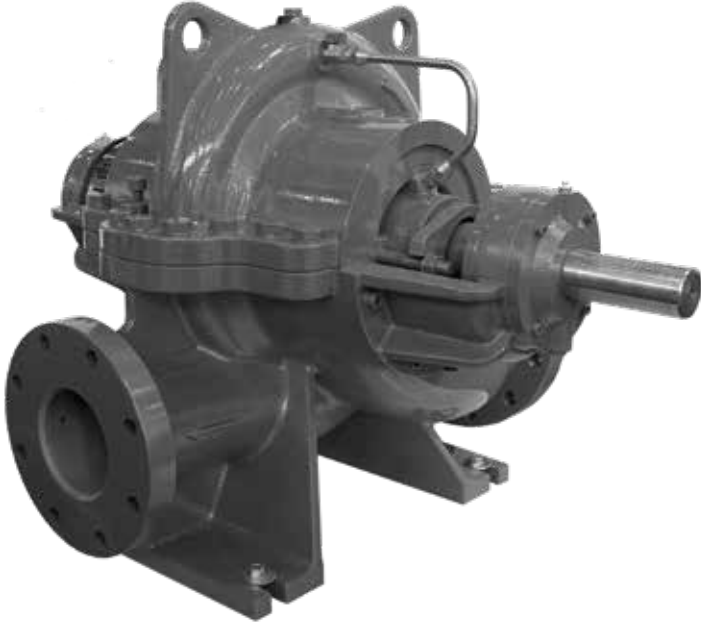

---

## Instruction for Operation and Maintenance



## SDS - UL/FM

---

**Double Suction Split Case Centrifugal Fire Pumps**

*yaşamı koru! save life!*

## **Instructions for Installation, Operation and Maintenance**

**Standart Pompa ve Makina San. Tic. A.Ş.**

**All rights reserved. Can not be copied or reproduced for any purpose without permission.  
Subject in the manual can be changed without any prior notice.**

**05.2019  
Revision 1**

## Contents

---

1. GENERAL	01
1.1 Safety Signs	01
1.2 General Instructions	01
1.3 Safety Instructions	01
1.3.1 CE signs and approvals	02
1.3.2 Personnel qualification and training	02
1.4 Recycling	02
2. GENERAL PUMP DESCRIPTION	03
2.1 Pump Description	03
2.2 Application Areas	03
2.3 Pump Designation	03
2.4 Pump Nameplate	03
2.5 Technical Information	03
3. UNPACKING, HANDLING and STRAGE	04
3.1 Unpacking	04
3.2 Handling	04
3.2.1 General warnings	04
3.2.2 Lifting operation	04
3.3 Storage	05
4. INSTALLATION SITE	05
4.1 Bare Shaft Pump	05
4.2 Preparation for Installation	05
4.3 Installation Site	05
4.3.1 General characteristics of the pump foundation (baseplate)	06
4.3.2 Placement of the Pump Group	06
4.4 Installation of the Piping System	07
4.4.1 General Warning	07
4.4.2 Suction Pipe	09
4.4.3 Delivery Pipe	09
4.4.4 Auxiliary pipe connections and accessories	09
4.5 Coupling Adjustment	10
4.6 Electrical Connections	11
4.7 Final Controls	12

## Contents

---

5. START UP / SHUT DOWN	13
5.1 Preparation	13
5.1.1 Lubrication Control	13
5.1.2 Venting and priming	13
5.1.3 Checking the direction of rotation	13
5.2 Start Up The Pump	13
5.3 Checks to be Made While The Pump is Running	14
6. LUBRICATION	14
6.1 Application of Grease on the Bearing	14
7. DISASSEMBLY AND REASSEMBLY	15
7.1 Disassembly	15
7.2 Reassembly	15
7.3 Tightening Torques	15
7.4 Shaft Seal	16
7.4.1 Pump with soft packing gland	16
8. SPARE PART	16
9. FAULTS, CAUSES AND REMEDIES	17
10. EXPECTED NOISE VALUES	18
11. SECTIONAL DRAWING	19
12. PART LIST	20
13. COUPLING GUARD AND SAFETY GUARD	20

## 1. GENERAL

The objective of this manual is to:

- Instruct the users on installation, dismantling, maintenance and repair of the pump, and
- Describe methods of start-up, operation and stop of the pump.

### 1.1 Safety Signs



#### General Risk

Signifies safety precautions which if not applied may cause vital.



#### Electrical Risk

Warnings about the electrical current



#### Warning

Safety instructions that if not applied may cause damage to the machine or operation.

### 1.2 General Instructions



**This manual should be made available at a safety place easily accessible by personnel responsible for safe operation and maintenance of the pump the qualified**

- The authorized personnel should be experienced and well - informed about the related standards.
- The instructions given in this manual should be carefully read and applied at any phase of the installation and operating process of the pump.
- The user is responsible to ensure that the inspection and installation are performed by the authorized and qualified personnel, who read this manual thoroughly.
- The pump should never be operated beyond the operating conditions set forth in the purchase order. The reason is that the operating conditions set forth in the purchase order have been taken into consideration in the selection of the pump material and trial of the pump.
- If the pump is required to be operated apart from the conditions set forth in the purchase order, please contact with **STANDART POMPA**. Standart Pompa does not assume any responsibility for any damages that may arise from operation of the pump beyond the specified conditions without written consent.
- If the pump will not be installed at its place immediately after delivery, it should be stored at a clean and dry place where the ambient temperature does not change excessively. If the proper precautions are not taken, excessively low or high temperatures may cause serious damages to the pump.
- **Standart Pompa** does not accept any responsibility under warranty for any repair or replacement performed by the user or any other unauthorized persons.
- This manual does not include safety rules applicable at the place of use.

### 1.3 Safety Instructions



**Always observe the following instructions to prevent any physical and/or property damages.**

- Operate the pump only under the specified pump.
- Any tension, contraction and strain on the piping system should never transfer to the pump.
- Electric wiring of the engine and auxiliary components should definitely comply with the local rules and be performed by the authorized personnel.
- Never perform any work on the pump before the pump set is stopped completely.



**Always disconnect power connection with the engine before you perform any work on the pump and make sure that no connection is made accidentally.**

- Any work on the pump should always be performed by at least two workers.
- Clothing of the personnel to work on the pump should always be suitable for the works they **will** perform and/or the personnel should use necessary safety equipment.
- The user personnel should take necessary warning precautions (e.g. warning signs, barricades, etc.).
- When the pump and pipes connected to the pump are under pressure, do not perform any work on the pump definitely.
- Once the work on the pump is over, put in place all safety shields previously removed.
- Never operate the pump in reverse direction.
- Never insert your hands and fingers into any hole or openings of the pump.
- Do not touch the pump and/or pipes connected to the pump.

### **1.3.1 CE signs and approvals**

It is a legal requirement that machinery and equipment put into service within certain regions of the world shall conform with the applicable CE Marking Directives covering Machinery and, where applicable, Low Voltage Equipment, Electromagnetic Compatibility (EMC), Pressure Equipment Directive (PED).

Where applicable, the Directives and any additional Approvals, cover important safety aspects relating to machinery and equipment and the satisfactory provision of technical documents and safety instructions. Where applicable this document incorporates information relevant to these Directives and Approvals. To confirm the Approvals applying and if the product is CE marked, check the serial number plate markings and the Certification, see the last page of this document.

### **1.3.2 Personnel qualification and training**

All personnel involved in the operation, installation, inspection and maintenance of the unit must be qualified to carry out the work involved. If the personnel in question do not already possess the necessary knowledge and skill, appropriate training and instruction must be provided. If required the operator may commission the manufacturer / supplier to provide applicable training.

Always co-ordinate repair activity with operations and health and safety personnel, and follow all plant safety requirements and applicable safety and health laws and regulations.

## **1.4 Recycling**

For products and parts which will not be used and scrapped, use the local or private waste collection services. If it is not possible, consult the nearest authorized service centre of STANDART POMPA.

# SDS PUMPS

## 2- GENERAL PUMP DESCRIPTION

### 2.1- Pump Description

• SDS series pumps are fire pumps which is designed in accordance with UL 448 and FM Class 1311 standards.

### 2.2- Application Areas

SDS series pumps are suitable for clean or slightly contaminated (max. 20 mg/dm<sup>3</sup>) liquids with low viscosities.

### 2.3- Pump Designation



SDS 100 - 250



Pump Type \_\_\_\_\_

Discharge nozzle (DN-mm) \_\_\_\_\_

Nominal impeller diameter (mm) \_\_\_\_\_

### 2.4 Pump Nameplate

			
WWW.STANDARTPOMPA.COM		CENTRIFUGAL FIRE PUMP - SPLIT CASE	
CE		3TP5	
TYPE	SERIAL NO		
SDS ... - ...	....		
	D	NO. STAGES	
	.... MM	...	
Q (RATED)	@	H (RATED)	N (RATED)
.... GPM		.... PSI	.... RPM
MAX. NET PRESSURE DEVELOPED		: ... PSI	
NET PRESSURE AT %150 CAPACITY		: ... PSI	
MAX. BHP		: ... HP	
MAX. POSITIVE SUCTION PRESSURE		: ... PSI	

			
WWW.STANDARTPOMPA.COM		CENTRIFUGAL FIRE PUMP SPLIT CASE	
CE			
TYPE	SERIAL NO	D	NO. STAGES
SDS ... - ...	....	.... MM	...
Q (RATED)	@	H (RATED)	N (RATED)
.... GPM		.... PSI	.... RPM
MAX. NET PRESSURE DEVELOPED		: ... PSI	
NET PRESSURE AT %150 CAPACITY		: ... PSI	
MAX. BHP		: ... HP	
MAX. POSITIVE SUCTION PRESSURE		: ... PSI	
DRIVER MAN. AND SERIAL NO.		CONTROLLER MAN. AND SERIAL NO.	
..... * .....		..... * .....	

### 2.5- Technical Information

Suction and Discharge Flanges : ANSI B16.42 Class 150/300

Speed : up to 3000 rpm

Ambient Temperature (max) : 40 ° C

Permissible Liquids : See Section 2.2

The service life of this product as determined and announced by the Ministry is 10 years.

(\*) **Note: Contact our company for more detail.**

### 3- UNPACKING, HANDLING and STORAGE

#### 3.1- Unpacking

- Check whether the package has been damaged during transportation.
- Remove unpackaged pump and accessories (if any) carefully. Check whether they have been damaged during transportation.
- If any damage has occurred during transportation, notify SERVICE DEPARTMENT, **STANDART POMPA** and SHIPPING COMPANY about it immediately.
- Check whether all materials in the shipping list have been delivered. If there is any missing article, advise SERVICE DEPARTMENT, **STANDART POMPA**.
- Remove the liquid inside the pump, for preventing corrosion due to transportation.

#### 3.2- Handling

##### 3.2.1- General warnings



- Follow the rules at work to prevent occurrence of any accidents.
- Wear gloves, steel-tooled shoes and helmet during handling.
- You may use forklift, crane or hoisting ropes to lower wooden crates, packages, pallets or boxes depending on volume, weight and construction of them.

##### 3.2.2- Lifting operation



ATTENTION

- Determine the following points prior to lifting and handling the pump or pump and motor group on the joint frame.

- Total weight and centre of gravity, - The largest outer dimensions, and
- Location of the lifting points.
- The load lifting capacity should comply with the weight of the pump or pump group.
- The pump or pump group should always be lifted and handled horizontally.
- Never stand under or near the load being lifted.
- Do not keep the load lifted longer than necessary.
- Accelerating and braking operations during the hoisting should not be performed in such a way that may be dangerous for the working personnel.

The pump or pump group should be hoisted as shown in the **Figure 1a** or **Figure 1b** in order to avoid from any deformation. (When the group is hoisted as a whole, never use the suspension hook of the electric motor.

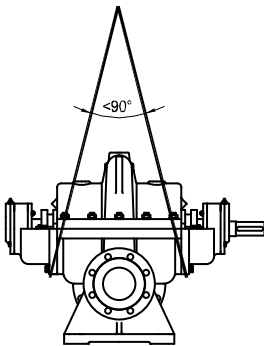

Fig 1a. Bare shaft pump

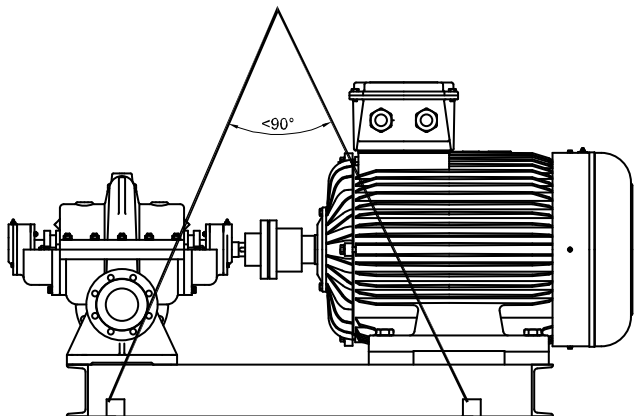

Fig 1b. Pump and motor



### 3.3- Storage

- If the pump will not be installed in place immediately, it should be stored at a clean and dry place free of any frost hazard without excessive change in the ambient temperature.
- If the pump bearings are of grease-applied ones, extra grease should be applied to the bearings to prevent moisture ingress around the shaft.
- Necessary precautions should be taken to protect the pump against humidity, dust, dirt and foreign materials.
- The pump should be rotated manually by some turns occasionally (e.g. once in a week) to prevent pitting on the bearing surfaces and sticking of the pump.

## 4- INSTALLATION ON SITE

**ATTENTION** Installation on site should be performed as per NFPA 20 standard.

Installation of the pump on site and levelling and adjustments of it should be performed only by qualified personnel. Improper installation or pump base (foundation) may cause failure. Such situations are excluded from warranty.

### 4.1- Bare Shaft Pump

- If the pump is purchased as bare shaft pump, then first a proper baseplate should be constructed to connect the pump and motor group. The baseplate should be designed and manufactured in such a way that it will have resistance to prevent vibration and deformation.
- If the pump is supplied without motor, proper motor and coupling should be selected before the group is installed.
- Following points should be taken into consideration when selecting motor:
  - Maximum power drawn by the pump along the entire operating range,
  - Running speed of the pump,
  - Applicable power supply (frequency, voltage, etc.),
  - Motor type (IEC, NEMA),
  - Motor connection form (pedestal, flanged, horizontal, vertical, etc.), and
- Rated motor power, rpm and type of drive should be taken into consideration when selecting coupling.

### 4.2- Preparation for Installation

Prior to installation of the pump in place:

- Suction and delivery flanges should be cleaned thoroughly.
- Protective film on the pump shaft should be removed.
- If the pump has been stored temporarily, the liquid oil in the bearings should be drained completely (in case of pumps manufactured with liquid oil) and the bearings should be cleaned by a proper cleaning agent and then oiled again. This operation is not required for the pumps lubricated by grease and for the pumps using enclosed type of ball bearing.

### 4.3- Installation Site

**ATTENTION** • The pump should be installed at a well-ventilated place free of freezing and explosion risk.

- There should be sufficient space around the pump being installed to allow easy access for maintenance of the pump as well as sufficient space above the pump to hoist it when required.
- Suction pipe of the pump should be short as far as possible.

### 4.3.1- General characteristics of the pump foundation (baseplate)

**ATTENTION**

You should work carefully for preparation of the pump base and installation of the pump group in place. Improper and careless installation may cause excessive vibration and premature wear of the pump equipment as well as pump failure.

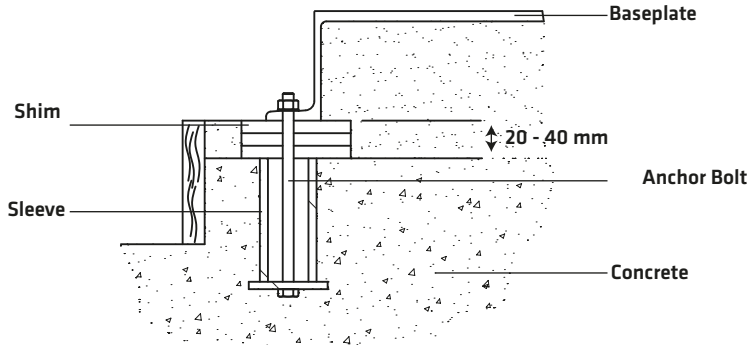

*Figure 2. Foundation, baseplate and anchor bolt*

- Sizes of the foundation concrete should be determined on basis of minimum 10% excess of the frame dimensions.
- Pump foundation should be independent of other foundation and platforms.
- Pump foundation should be capable to absorb vibrations and bear the loads to apply on the pump unit during operation.
- Place and dimension of the anchor bolts should be determined according to the hole dimensions of the pump unit.
- Washer should be used to prevent tension and distortion when tightening the foundation bolts.
- In order that the foundation bolts should align with the connection holes of the frame exactly and to allow for minor adjustments, the bolts are inserted into the bushings. The bushings should be place in such a way that they will not exceed top surface of the foundation concrete.

### 4.3.2- Placement of the Pump Group

- Preparation and pour of the foundation concrete mass.
  - The concrete mass is formed according to its dimensions.
  - The locations of the anchor bolts are measured and marked carefully and Styrofoam is cut to the dimension, placed and fixed.
  - The concrete is poured
    - Volume ratio: Cement 1: sand 2: gravel 4
    - Concrete hardens within 7 days (hardening may be shortened by use of special cement).
  - Upon hardening of the concrete, the Styrofoam is burned and removed. Locations of anchor bolts appear in the concrete.
  - Top surface of the concrete and holes of the anchor bolts are cleaned.
- Placement of the frame on the foundation concrete mass. (first adjustment)
  - Anchor bolts are mounted on the frame.
  - The frame is placed on the flattening chocks and the anchor bolts remain suspended in the holes. Make sure that the anchor bolts remain vertical.
  - Levelness of the frame is controlled in both directions from the pump and engine placement location by use of precise spirit level  $0,25 \div 0,40$  mm/m is acceptable.
  - Anchor holes are filled with concrete. Anchor bolts are thus fixed.

Volume ratio: Cement 1 : sand 1.5: gravel 3

Concrete hardens within 7 days (hardening time may be shortened by use of special cement).

- Fixing of the frame on the foundation concrete mass exactly by adjustment.

- The area about 30mm between the foundation concrete mass and frame is formed and concrete is poured through the holes in the frame.

- Volume ratio: Cement 1: sand 2

- Concrete hardens within 2 days.

- Frame remains adjusted and fixed on the foundation concrete.

## 4.4- Installation of the Piping System

### 4.4.1- General Warning

**ATTENTION** • **Never use the pump as a point of support or bearer for the piping system.**

- The piping system should be supported at points near to the pump. For this purpose, after completion of the installation of the piping system, loosen the bolts of the suction and delivery flanges and control whether the piping system applies any tension on the pump. The maximum allowable forces and moments on the flanges are given in **Table 1**.
- Rated diameter of the suction and delivery flanges of the pump are not indicator of the correct sizes of the suction and delivery pipes at all. The rated diameter of the pipes and accessories used should be equal to or larger than the inlet diameters of the pump at least. Never use pipes and accessories having smaller diameter than the inlet diameters of the pump. Especially components such as, strainer, dirt-retaining filter and check valves with larger free passage area should be preferred.
- Pipe connections should be made with the flanges. Flange bolts should be made of proper material and in proper size. The flange bolts should be inserted between the flange bolts and centred in such way that it would not impair flow section.
- In case of excessive vibrations, expansion parts should be used in order that any extra forces that may arise from thermal expansion are not transferred to the pump.
- Materials such as welding burrs, metal particles, sand and oakum arising from production of the piping system may remain in the pump and give damage to the pump. The suction and delivery flanges should be sealed blind washers in order to prevent such materials from entering into the pump during the assembly operations. After assembly, all pipe parts should be removed, cleaned, painted and reassembled. If dirt-retainer is used on the suction side of the pump, the dirt-retainer should be cleaned after working for several days.

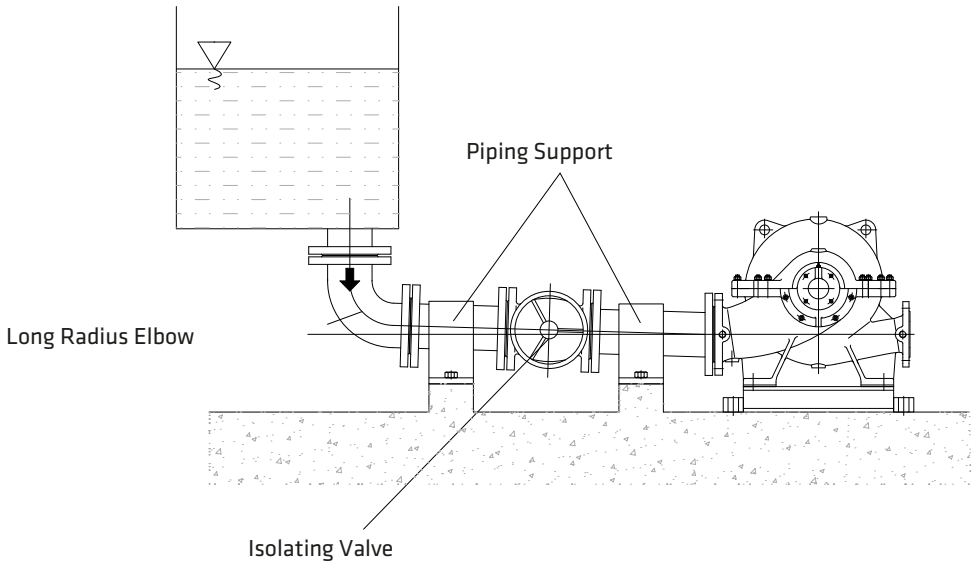
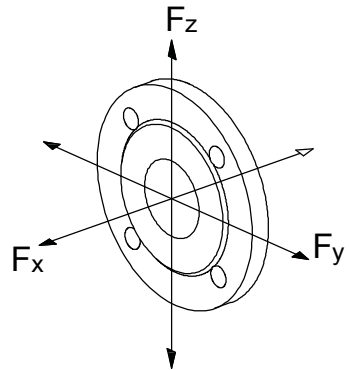

**Fig 3. Suction Head**

**Allowable Forces and Moments on Flange**

Pump Type	Suction Flange										Discharge Flange							
	DN	F <sub>x</sub> [N]	F <sub>y</sub> [N]	F <sub>z</sub> [N]	ΣF [N]	M <sub>x</sub> [Nm]	M <sub>y</sub> [Nm]	M <sub>z</sub> [Nm]	ΣM [Nm]	DN	F <sub>x</sub> [N]	F <sub>y</sub> [N]	F <sub>z</sub> [N]	ΣF [N]	M <sub>x</sub> [Nm]	M <sub>y</sub> [Nm]	M <sub>z</sub> [Nm]	ΣM [Nm]
65-250	100	1690	1560	1430	2730	690	500	570	1020	65	1100	960	880	1690	590	430	470	860
80-250 80-315	125	2080	1820	1690	3250	820	590	740	1200	80	1300	1170	1070	2080	620	460	510	920
100-250	150	2600	2340	2080	4030	980	690	810	1430	100	1690	1560	1430	2730	690	500	570	1020
125-315	200	3510	3120	2860	5460	1280	900	1040	1820	125	2080	1820	1690	3250	820	590	740	1200
150-315	200	3510	3120	2860	5460	1280	900	1040	1820	150	2600	2340	2080	4030	980	690	810	1430

**Table 1**



#### 4.4.2- Suction pipe

- The suction pipe should be definitely watertight and should not be arranged in a way to cause formation of air pockets. **Figure 3**
- In order to keep the loss from friction, sharp elbows should not be used; and abrupt change of direction and section should be avoided and suction pipe should be made short as far as possible. If it is required to make change of section on a horizontal suction pipe, an eccentric conical spacer with its flat side on the top should be used.

- An insulation valve should be

**ATTENTION**

used to keep the axis on the suction pipe horizontally. This valve should always be open when the pump operates and it should never be used as flow rate adjusting valve (Caution: Throttle of the valve may cause the pump to operate with cavitation).

#### 4.4.3- Delivery pipe

- A flow control valve should be connected on the delivery pipe, near the pump as far as possible in order to adjust the flow rate and delivery head. **Figure 4**

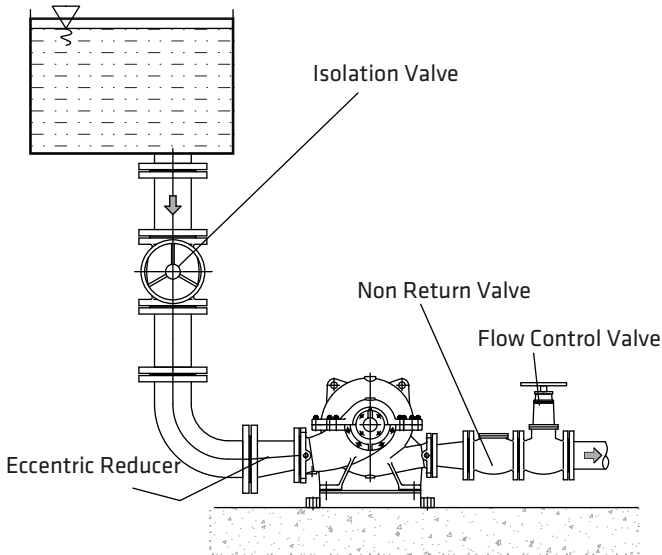

**Fig 4. Suction Head**

**ATTENTION**

After installation of piping system, coupling alignment should be checked and if necessary it should be adjusted again.

#### 4.4.4- Auxiliary pipe connections and accessories

- Depending on the application auxiliary pipe connections (for cooling, sealing and flushing of seal, drainage etc. necessary for the pumping system) and/or accessories to check operating conditions (pressure gauges, temperature gauges etc.) may be made up and lail.
- Pressure and vacuum gauges must be properly anchored and connected at the measuring points located on the pump flanges by means of or on the pipes close to the flanges. For safety purposes isolating and vent valves should be fitted before the gauges.
- Cooling, sealing and flushing of seal piping must be connected only to the designated connections located on the pump.

## 4.5- Coupling Adjustment

**ATTENTION** After installation of the baseplate and system connections, the coupling adjustment should be controlled finally. The reason that proper adjustment of the entire system is responsibility of the purchaser.

**ATTENTION** “Coupling Adjustment” is to ensure that the rotation axes of the motor and pump should be on the same plane. SDS type pumps are ordered with motor and baseplate, they are delivered with the coupling adjustments made at the factory. However, this adjustment may be easily impaired during transportation, handling, installation on site and installation of the system. For this reason, the coupling adjustment should be performed again after installation of the group on site, disregarding the adjustment made at the factory.

- The most important factor for problem-free operation of the pump group is correct coupling adjustment. The basic reason of a number of problems such as vibration, noise, bearing heating and overload is a coupling unadjusted or improperly adjusted. For this reason, coupling adjustment should be performed very well and controlled frequently.

- Elastic coupling should not be regarded as a component to correct an improper adjustment. Elastic coupling does not correct a poor axial adjustment between the pump and motor and does not remove excessively poor adjustments.

- A metal part (steel ruler or gauge, etc.) and a precise caliper are required to perform coupling adjustment (special equipment should be used for very fine and precise adjustment). Axial run-out of the coupling (see Figure 5) should not exceed 0.1 mm.

- There may be two types of adjusting mistakes on the coupling:

- a) Angular mistake
- b) Parallel displacement mistake

- In order to control the angular mistake, the distance between two parts of the coupling should be measured mutually on horizontal and vertical planes. The clearances measured at these four points should be equal (Figure 6a,6b).

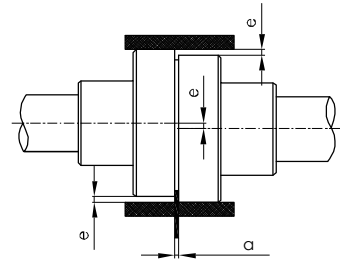

Fig 5. Aligning a flexible coupling

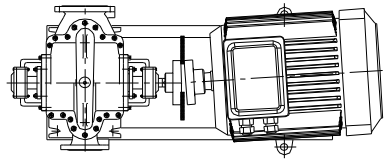

Fig 6a. Angle error in horizontal plane and adjustment

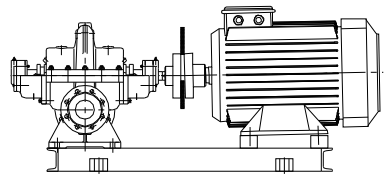

Fig 6b. Angle error in vertical plane and adjustment

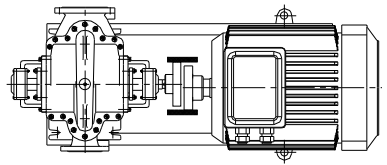

Fig 6c. Parallel sliding error in horizontal plane and adjustment.

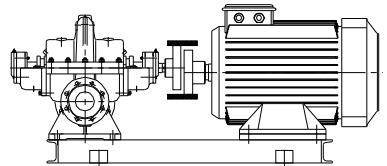

Fig 6d. Parallel sliding error in vertical plane and adjustment.

- In order to control the parallelism mistake, a gauge with straight edge is pressed on a part of the coupling in parallel to the axis and the position of the gauge related to other part is observed. The gauge should contact with both two parts simultaneously and along its entire edge. This process should be performed at two opposite places on the horizontal and vertical plane (**Figure 6c, 6d**).
- Adjustment mistakes may be on the horizontal and/or vertical plane. Mistakes on the vertical plane may be made by putting thin metal sheets under the pump or motor mounts and the mistakes on the horizontal plane by benefiting from the gaps in the connection holes or sliding the engine on the horizontal plane. Manner and order of the coupling adjustment is shown in the **Figures 6a, 6b, 6c and 6d**, respectively.

#### **4.6- Electrical Connections**

- Electrical connection should be done by a qualified electrician. Current national regulation and motor manufacturer's instructions must be observed.
- Take all safety precautions listed in "Safety instructions". Disconnect all power supplies prior to doing any work.
- The supply cable must be laid in such a way that it never touches the pipework, pump and motor casing.
- Check voltage, phase and frequency on motor nameplate with the mains.
- The electric motor must be protected against overloading by means of circuit breakers and/or fuses. Circuit breakers and fuses must be selected in accordance with full load amperage of the motor appearing on the motor rating plate.
- Prior to connection the electrical wiring rotate the pump shaft by hand to make sure rotor rotates easily.
- Connect the electrical wiring in accordance with local electrical codes and make sure to ground the motor.
- The connection diagram can be found in the terminal box of the motor or in the instruction manual.
- The mains connection on the terminal box depends on the nominal power of the motor, the power supply and the type of connection. The necessary connection of the bridges in the terminal box is shown in the following (**Table 2 ve Figure 7a, 7b, 7c**).

Type of switch	Motor Power $P_N \leq 4 \text{ kW}$	Motor Power $P_N > 4 \text{ kW}$
	Power Supply 3 ~ 400 V	Power Supply 3 ~ 400 V
direct	Y - connection (11b)	$\Delta$ - connection (11a)
Y / $\Delta$ - start	Impossible	Remove connection bridges (11c)

**Table 2**

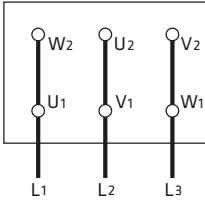

**Figure 7a.**  $\Delta$  - connection

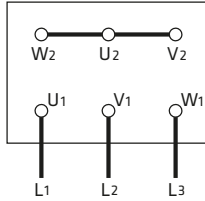

**Figure 7b.** Y - connection

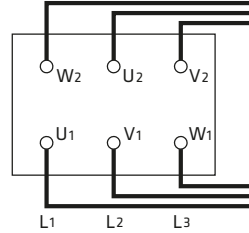

**Figure 7c.** Y /  $\Delta$  - connection

**ATTENTION**

In the case of three-phase induction motors with Y -  $\Delta$  connection it must be ensured that the change-over points between star and delta follow on from one another very quickly. Longer change-over times may result in pump damage (Table 3).

Motor Power	Y - set time
$\leq 30 \text{ kW}$	< 3 second
> 30 kW	> 5 second

**Table 3**

#### 4.7- Final Controls

- After all operations given above are completed, the coupling adjustment should be controlled once more in accordance with the **section 4.5**. And if it is incorrect, it should be corrected.
- The pump rotor should be rotated several times manually to make sure it rotates easily.
- All security guards should be put in place.
- And the pump group should be operated and you should allow until the operating and heating conditions are reached.
- At the end of this term, the pump is stopped and thin metal sheets are put under the motor mounts only to perform coupling adjustment for the last time.
- Final coupling adjustment is especially recommended to be performed at the operating temperature.



- The pump should never be operated before the safety guards are put in place. This is a security and safety rule at workplace which should be definitely observed.



## 5- START UP / SHUT DOWN

### 5.1- Preparation

#### 5.1.1- Lubrication control

- The bearings of SDS type pump are always lifetime grease lubricated. Lifetime grease lubricated bearings are maintenance-free.

#### 5.1.2- Venting and priming

- Make sure that the pump and suction pipes are completely filled up with water. There is no problem for the pumps which have positive suction head. If there is a valve on suction line, it must be opened and air taps are loosened to enable the water replaces air in the pump, until it is completely full with water.

**ATTENTION** Make sure the pump never runs dry.

#### 5.1.3- Checking the direction of rotation

- SDS type pumps rotate in clockwise when it is looked from coupling to the pump. This direction is already indicated on the pump by an arrow. Check this by switching the pump on, then off again immediately. Fit the coupling guard back in place if you took it out.

### 5.2- Start Up The Pump

- Check if the shut off valve in the suction line is open.
- Switch on the circuit breaker and run the motor.
- Wait until the motor reaches the full speed (on star-delta running motors wait until it switches on delta).

**ATTENTION** The pump should be shut down at once and the trouble should be corrected if the pump is running at its rated speed and found any of the following faults:

- Pump doesn't deliver any water,
- Pump doesn't deliver enough water,
- Flow is going down,
- Discharge pressure is not enough,
- Driver overloaded,
- Vibration on pump,
- High noise level,
- Bearing overheating.

### 5.3- Checks to be Made While The Pump is Running

**ATTENTION**

- The pump must never run dry.
- **Never run the pump for along period against a closed discharge valve (at zero flow)**

- The bearing temperature may exceed the ambient temperature by up to 50 °C. But must never rise above 80 °C.
- The valves in the auxiliary lines must remain open while the pump is running.
- The pump has soft packing type stuffing boxes. These should drip during operation. The gland nuts should only be lightly tightened. In case of excessive leakage from the stuffing box tighten the gland nuts slowly and evenly until the leakage is reduced to the dripping state. Check the stuffing box for overheating by hand. If the gland nuts can not be tightened any further remove the old packing rings. Make sure that each packing ring is cut of correct size. The joint in successive ring should be offset to each other.
- The flexible coupling elements should be regularly checked and replaced as soon as they are shown signs of wear.
- Occasionally check the motor current. Stop motor if the amperage is higher than usual; there may be jamming or friction in the pump. Make the necessary mechanical and electrical checks.
- Stand-By pumps should be run for a short time at least once a week to ensure they are in constant readiness for operation. Check the integrity of auxiliary connections.

## 6- LUBRICATION

- Bearing of SDS type pumps have grease lubricated ball bearings.
- Life-time grease lubricated bearings are maintenance free.
- See the attached **Table 4** for bearings type and size.

Pump Dimension Group	Shaft end Dimension $\varnothing$	Bearing Type
A	35	6308 C3
B	42	6310 C3
C	55	6312 C3

*Table 4*

### 6.1- Application of Grease on the Bearing

High quality NLGI 2 or NLGI 3 grease must be used in bearings.

The grease must be replaced in every 12-14 months or at the end of each 3000 working hours.

More frequent grease replacement may cause overheating and shortening of the bearing life.

**ATTENTION**

**The bearing temperature must never exceed the ambient temperature by maximum 50 °C. Also, it must not exceed 80 °C under no circumstances.**

The bearings of the pumps demounted for repair must be inspected and replaced, if necessary.

It must be ensured that the greasing equipment and the reservoir are clean before adding grease to the bearings.

Grease in suitable amounts must be added to the bearings.

The temperatures of the bearings may increase in the case of adding excessive amount of grease.

The temperatures of the bearings will decrease to the normal operating temperature when excessive grease is removed.

## 7- DISASSEMBLY AND REASSEMBLY

- Follow the safety precaution measures outlined in “safety instructions”.

### 7.1- Disassembly

- Close all valves in the suction and discharge lines, and drain the pump by opening the drain plug and the air plug.
- Disconnect the stuffing boxes flushing pipes.
- Remove coupling guard and other safety guards (see section safety guard).
- Remove all casing main joint nuts and dowel pins.
- Separate the casing halves, lifting off the upper half casing. This reveals the pump internals (impeller, wear rings) for inspection.
- Unscrew the bolts which are connecting the bearing housings to the bottom half casing.
- Remove bearing covers and bearing end covers.
- Pull the bearing housing off the bearings.
- Unscrew the shaft nuts and lock washers.
- Pull the bearing off the shaft and remove.
- Remove in sequence bearing covers, throwers, spacer sleeves, stuffing boxes, shaft protecting sleeves, wear rings, impeller and impeller key.
- Clean all the parts, replace damaged or worn-out ones.

### 7.2- Reassembly

- Reassembly proceeds in reverse sequence to dismantling as described in (section 7.1). You may find the attached drawing useful. the following points should be noted more particularly.
- Never use old o-rings and make sure the new o-rings are the same size as the old ones.
- Before mounting the shaft protecting sleeves inspect the condition of their rubbing faces. Use new sleeves if the old ones are badly worn, scored or rough.
- the joint faces of the casing halves are sealed with liquid sealing compound. The joint faces should be thoroughly cleaned before reassembly and coated over again with sealing compound. NEVER USE A PAPER GASKET BETWEEN THE TWO FACES.

### 7.3- Tightening Torques

**ATTENTION** The following tightening torques must be taken into consideration when tightening the bolts and nuts during installation.

Thread Diameter	Tightening Torques (Nm)
M6	7
M8	20
M10	40
M12	65
M14	100

**Table 5**

Thread Diameter	Tightening Torques (Nm)
M16	130
M18	140
M20	140
M22	140
M24	200

**Table 5 (continue)**

## 7.4- Shaft Seal

### 7.4.1- Pump with soft packing gland

- While starting to change soft packing thoroughly clean the stuffing box and shaft (or shaft sleeve, if used).
- Cut enough number of pieces suitable length diagonally from suitable size of soft packing. Roll it up over the shaft (or shaft sleeve, if used) and see the ends are in full contact.
- Insert the first packing ring as the joint will place up, and press home using the gland cover.
- Place the second ring as joint will place down. Insert all the packing rings in the same way. If there is a lantern ring put into place too.
- Place the gland and fully tighten, thus the packing rings will take the shape of stuffing box, the loosen it. Slightly tighten by turning the shaft and stop tightening when it slightly brakes the shaft.
- After starting operation, it is necessary that water drips from the packing. This dripping shouldn't be less than 10 cm<sup>3</sup>/min and more than 20 cm<sup>3</sup>/min. Adjust dripping by uniformly tightening or untightening the gland nuts slightly.
- Check the temperature of soft packing after two hours operation after gland adjustment to avoid overheating.

Pump Dimension Group	Shaft End Diameter ∅	Yumuşak Salmastra Kesiti □
A	35	12x12
B	42	12x12
C	55	16x16

**Table 6**

## 8- SPARE PART

- STANDART POMPA guarantees to supply the spare parts for SDS type pumps for 10 years. You can provide any spare parts easily.
- Lets us know the following details on the name-plate, when you order spare parts.

Pump Type : (SDS 125-315)  
 Serial No : (..... - .....)  
 Q (Rated) / H (Rated) : (1500 gpm - 150 psi)

- If you prefer to have spare parts in your stock, we recommed you to have the following quantities for two years operation depending on the number of same of pumps (**Table 7**).

Part No	Part Name	Number of pumps in the system						
		2	3	4	5	6-7	8-9	10+
60	Shaft (incl. keys) (piece)	1	1	2	2	2	3	30%
50	Impeller	1	1	1	2	2	3	30%
20	Wear Ring	4	4	4	6	6	8	50%
200	Ball Bearings	2	2	4	4	6	8	50%
70	Shaft Sleeve	4	4	4	6	6	8	50%
400	Soft Packing (set)	8	8	12	12	12	16	40%
420	Casing O-Ring	4	6	8	8	9	12	150%

**Table 7**

## 9- FAULTS, CAUSES AND REMEDIES

In this section you will find operating faults which may arise, and their causes (**Table 8**), and suggested remedies (**Table 9**).

FAULTS	POSSIBLE CAUSES
Pump does not deliver any water after start-up	1-5-7-10-11-13
Flow is going down or no flow at all	1-2-3-4-6-7-8-14
Driver overloaded	9-12-17-18-19-27-28
Bearings overheating	19-20-21-22-24
Vibration on pump	6-9-15-16-19-23-25
Noise level is high	4-6-26

**Table 8**

	POSSIBLE CAUSES	REMEDY METHODS
1	May be air in the pump and/or suction line	Fill the pump and suction pipe with liquid completely and repeat the start-up operation.
2	Air intake from the seal, suction pipe or connections. Pump intakes liquid mixed with air.	Check all connections on the suction pipe. Check the seal and supply pressurized liquid to the seal, if required. Check immersion depth of the suction pipe or bottom valve and increase the immersion depth, if required.
3	Air pocket in the suction pipe	Check inclination of the suction line and whether there are parts susceptible to formation of air pockets and if there are make necessary corrections.
4	Air in the liquid	Eddies occur due to insufficient immersion depth of the suction pipe causing to air intake. Check liquid level in the suction reservoir or increase immersion depth of the suction pipe / bottom valve.
5	Suction depth too much	If there is no obstacle leading to clogging in the suction, check friction loss on the suction line and use suction pipe with large diameter, if required. If the static suction depth is too much, you should either increase the liquid level in the suction reservoir or move the pump to a lower level.
6	Pump operates with cavitation	NPSH of the plant is very low. Check the liquid level in the suction reservoir. Check whether there is excessive friction loss on the suction line. Check whether the insulation valve on the suction line is completely open. If required, reduce the pump to a lower level and increase load on the pump suction.
7	Delivery head of the pump is insufficient	Actual delivery head of the plant is higher than the specified one. Check the total static height and friction loss of the suction pipe. Use of pipe with larger diameter may act as remedy. Check whether the valves are completely open.
8	Increased delivery head	Check whether the valves are completely open. Check whether there is any obstacle causing clogging in the suction pipe.
9	Pump operates at a lower delivery head.	Actual delivery head of the plant is less than the specified one. Machine the impeller diameter in accordance with the manufacturer's recommendation.
10	Pump returns reverse.	Check whether the engine's direction of rotation complies with the direction of rotation indicated on the pump casing or name plate.

**Table 9**

POSSIBLE CAUSES		REMEDY METHODS
11	Low speed	Check mains voltage and frequency or whether there is phase faults in the engine
12	Speed too high	Reduce the pump speed, if possible or machine the impeller diameter according to the manufacturer's recommendation.
13	Impeller, check valve or strainer clogged	Clean the impeller, check valve or strainer.
14	Impeller or strainer partly clogged	Clean the impeller or strainer.
15	Impeller partly clogged.	Clean the impeller.
16	Worn or broken impeller	Replace the impeller
17	Mechanical friction on the pump	Check whether there is obstacle or bending on the pump rotor.
18	Soft seals worn excessively	Loosen pressure bush of the seal
19	Coupling misadjusted	Check coupling rubber and readjust it.
20	Bearing covers too tight	Check the covers and make necessary corrections.
21	Flow rate is less than the required minimum flow rate	Increase the flow rate. Use by-pass valve or line, If required.
22	Too much grease on the bearing	Remove the excess grease.
23	Bent shaft	Check the shaft and replace it, if required.
24	Insufficient lubrication or lubricant contaminated.	Check amount of the lubricant. Clean the bearings and bearing housings and lubricate again.
25	Instable rotating parts	Check stability of the rotating parts.
26	Pump operates beyond the area of operation	Check the values of the area of operation
27	Density or viscosity of the delivered liquid is more than the specified value.	Use engine of higher power.
28	Enging fault	Check the engine. Engine ventilation is not proper due to its position.

**Table 9 (continue)**

## 10- EXPECTED NOISE VALUES

Motor Power - P <sub>N</sub> (kW)	Sound Pressure level (dBA) * (Pump and Motor)
	2900 rpm
55	84
75	85
90	85
110	86
132	86
160	86

**Table 10**

(\*)The values measured at a distance of 1 m from the pump in the free area on the sound reflecting surface without sound curtain

(\*)These values apply if the pump is operated in normal ordered operating values without cavitation.

(\*)If the pump is operated at 60 Hz; increase the values in the table by 1 dB for 1800 rpm and by 2 dB for 3600 rpm.

11- SECTIONAL DRAWING

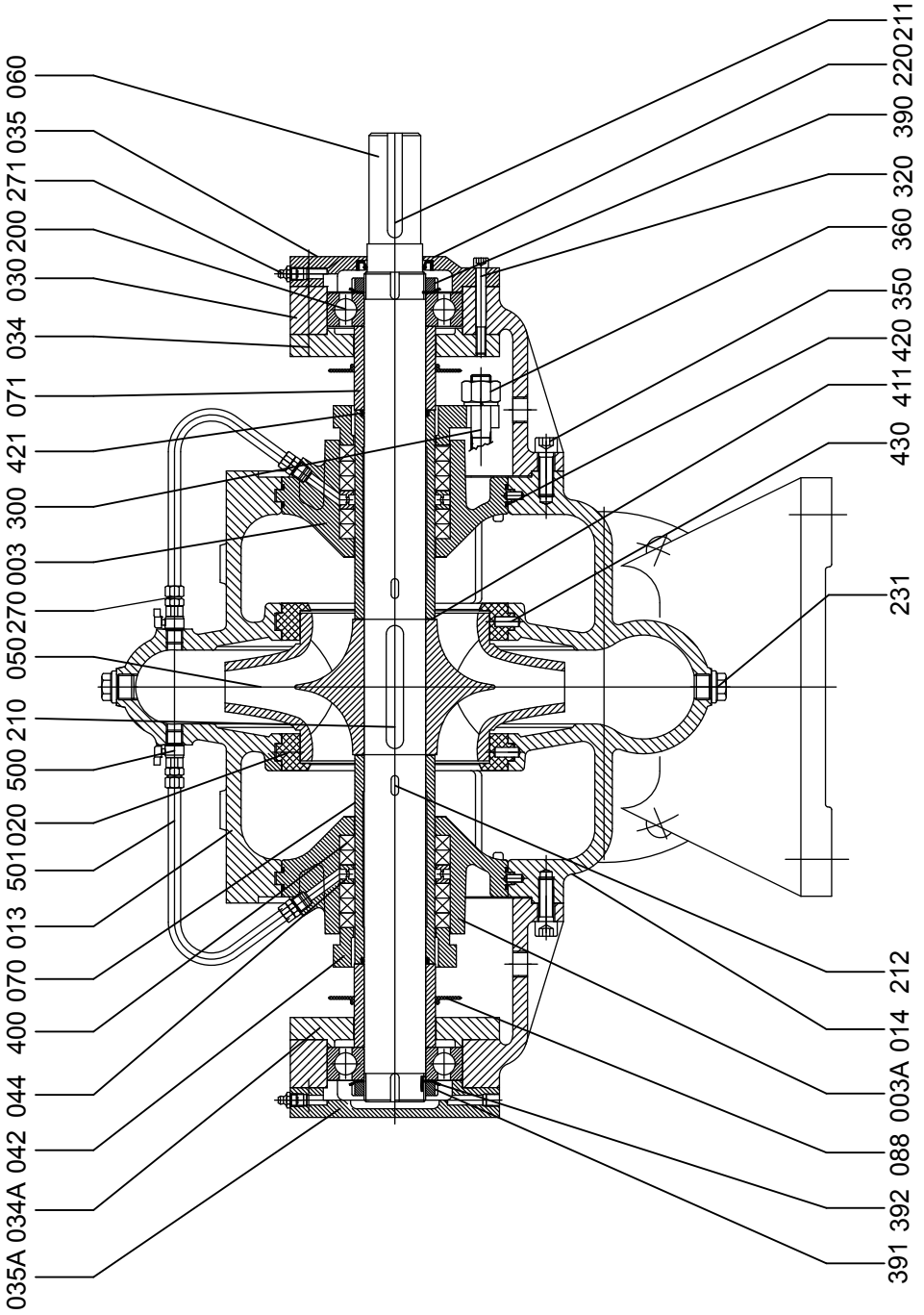

## 12- PART LIST

Part No	Part name	Part No	Part name
003	Stuffing Box (right side)	212	Key
003A	Stuffing Box (left side)	220	Oil Seal
013	Volute Casing (top)	231	Drain Plug
014	Volute Casing (bottom)	270	Nipple
020	Wear Ring	271	Grease Nipple
030	Bearing Housing	300	Stud
034	Bearing Cover (inboard)	320	Hex. Head Bolt
034A	Bearing Cover (inboard)	350	Allen Screw
035	Bearing Cover (outboard)	360	Nut
035A	Bearing Cover (outboard)	390	Locknut (non drive end)
042	Stuffing Box Gland	391	Locknut (drive end)
044	Lantern Ring	392	Lock Washer
050	Impeller	400	Stuffing Box Packing
060	Shaft	411	Gasket
070	Shaft Protecting Sleeve	420	O-Ring
071	Sleeve (spacer)	421	O-Ring
088	Thrower	430	Pin
200	Ball Bearing	500	Valve
210	Impeller Key	501	Flushing Pipe
211	Coupling Key		

## 13- COUPLING GUARD AND SAFETY GUARD

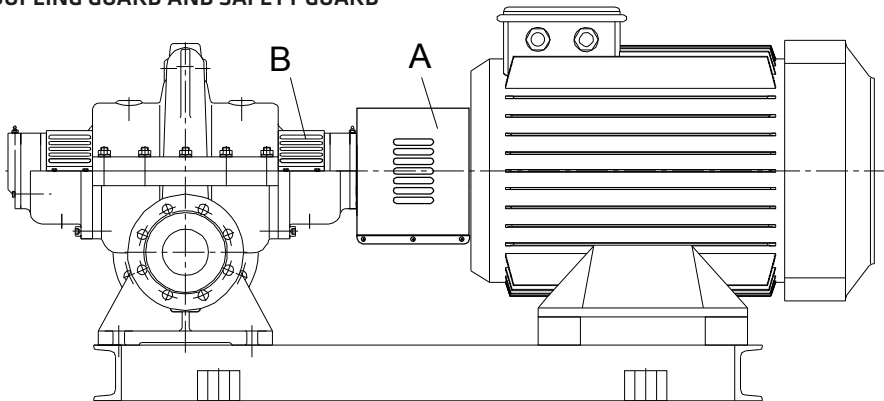

SAFETY GUARD

COUPLING GUARD

Not: All guards are conforming to EN 294.



## EC DECLARATION OF CONFORMITY

### MANUFACTURER NAME:

**Standart Pompa ve Makina San. Tic. A.Ş.**

Dudullu Organize San. Bölgesi 2. Cad. No:9 34776 Ümraniye / İSTANBUL

t: +90 216 466 89 00 f: +90 216 415 88 60 - www.standartpompa.com / info@standartpompa.com.tr

The undersigned declares that the described products meet the essential requirements of the below mentioned standards as based on Machinery Directive 2006 / 42 / EC .

The item of equipment identified below has been subject to internal manufacturing checks with monitoring of the final assesment by our company.This declaration refers to the machinery in delivery status.Any modifications of the machinery by the end user shall invalidate this declaration.

EQUIPMENT DESCRIPTION : Centrifugal Pumps MODEL/ TYPE : SDS

### DIRECTIVES:

**Machinery Directive 2006 / 42 / EC - Low Voltage Directive 2014 / 35 / EC**

### Regulations Applied acc. to HARMONIZE STANDARDS:

**EN ISO 809:1998+A1:2009, EN ISO 12100:2010, EN 60204-1:2006/AC:2010**

### The Person Authorised To Compile The Technical File

Fatih ÇOBAN

16.08.2016

İSTANBUL

### Signed On Behalf Of The Manufacturer

Şeref T. ÇELEBİ

Genel Müdür

**Standart**  
Pompa ve Makina  
Saraylı Ticaret Anonim Şirketi

## MANUFACTURER DECLARATION OF CONFORMITY

### Products: Pumps of type SDS (bareshaft)

**Standart Pompa ve Makina San. Tic. A.Ş.**

Dudullu Organize San. Bölgesi 2. Cad. No:9 34776 Ümraniye / İSTANBUL

t: +90 216 466 89 00 f: +90 216 415 88 60 - www.standartpompa.com / info@standartpompa.com.tr

The manufacturer here with declares that the described products meet the essential requirements of Machinery Directive **2006 / 42 / EC**.

Before the pump is put into operation, the machinery unit in which the pump is functioning to be declared in conformity to relevant regulations.

### Harmonised standards applied are;

- EN 809
- EN ISO 12100:2010

**Standart**  
Pompa ve Makina  
Saraylı Ticaret Anonim Şirketi

Şeref T. ÇELEBİ  
General Manager

Proteggere la vita  
Inochi o mamoru  
Yaşamı Koru  
Protéger la vie  
Save Life!  
Skydda Livet Schützen Sie Leben



All rights reserved. Can not be copied or reproduced for any purpose without permission.  
Subject in the manual can be changed without any prior notice.

Factory - Company  
Service

STANDART POMPA VE MAKİNA SANAYİ TİC. A.Ş.

Dudullu Organize Sanayi Bölgesi, 2. Cadde  
No: 9 34775 Ümraniye İstanbul / Türkiye  
T: +90 216 466 89 00 F: +90 216 499 05 59

[www.standartpompa.com](http://www.standartpompa.com) / [info@standartpompa.com.tr](mailto:info@standartpompa.com.tr)